



**CITY COUNCIL MEETING AGENDA
AUGUST 21, 2023, AT 6:30 PM
COUNCIL CHAMBERS**

The City Council is provided background information for agenda items in advance by city staff, committees, and boards. Many decisions regarding agenda items are based upon this information, as well as: City policy and practices, input from constituents, questions or information that has not yet been presented or discussed regarding an agenda item. If you have a concern or question, please ask to be recognized by the mayor during the "Citizens addressing the Council" portion of the agenda.

1. Call Meeting to Order and Pledge of Allegiance
2. Roll Call
3. Approval of the Agenda
4. Citizens Addressing the Council

State your name and address for the record. Please keep comments under 5 minutes. Individuals wishing to speak for more than five minutes should ask to be included on the agenda in advance. All comments are appreciated, but please refrain from personal or derogatory attacks on individuals.

CONSENT AGENDA

5. Approval of Consent Agenda
 - A) Approval of Bills
 - B) August 7, 2023, City Council Meeting Minutes
 - C) Approval of Liquor License for Bull Riding Event at Sibley County Fairgrounds-September 8 & 9

OLD BUSINESS

6. Christian Lilienthal speaking on tax forfeiture.
7. Golf Cart Ordinance
8. Update on Cannabis

NEW BUSINESS

9. RESOLUTION 30-2023- A RESOLUTION AMENDING THE 2023 CITY CALENDAR
10. Street Maintenance Bids, Kirby Weckworth
11. Door Bid, WWTP

REPORTS OF OFFICERS, BOARDS AND COMMITTEES

12. Submitted Police Report from July
13. City Administrator Update, Jessica Steinke
14. City Attorney Update, Ken Janssen

MISCELLANEOUS BUSINESS

ADJOURNMENT

***Check Summary Register©**

10150 Unposted

	Name	Check Date	Check Amt
10150 Cash			
Unposted	BORDER STATES ELECTRIC	8/18/2023	\$5,863.12
Unposted	BOUND TREE MEDICAL, LLC	8/18/2023	\$180.66
Unposted	CEDA	8/18/2023	\$9,969.23
Unposted	FERGUSON WATERWORKS	8/18/2023	\$3,619.76
Unposted	FillMeUp	8/18/2023	\$1,521.66
Unposted	FRITZ'S TINT SHOP	8/18/2023	\$480.00
Unposted	IMPRINTS LABEL & DECAL	8/18/2023	\$315.00
Unposted	JERRY'S HOME QUALITY FOODS	8/18/2023	\$257.28
Unposted	KURT MENK	8/18/2023	\$24.53
Unposted	LEAGUE OF MN CITIES INS. TRU	8/18/2023	\$56,143.00
Unposted	LEAGUE OF MN CITIES	8/18/2023	\$336.20
Unposted	LINDE GAS & EQUIP	8/18/2023	\$420.83
Unposted	LOFFLER	8/18/2023	\$91.38
Unposted	MCLEOD COOPERATIVE POWER	8/18/2023	\$46,264.11
Unposted	MCLEOD PUBLISHING	8/18/2023	\$407.65
Unposted	MIDWEST PLAYSCAPES, INC.	8/18/2023	\$120.00
Unposted	MINI BIFF, LLC	8/18/2023	\$818.04
Unposted	MN MUNICIPAL POWER AGENCY	8/18/2023	\$232,394.83
Unposted	MORRIS ELECTRONICS	8/18/2023	\$3,199.70
Unposted	PEARSON BROS. INC.	8/18/2023	\$24,564.75
Unposted	PREMIER LOCATING, INC.	8/18/2023	\$2,722.00
Unposted	SIBLEY COUNTY ASSESSOR	8/18/2023	\$10,940.00
Unposted	SIBLEY EAST - COMMUNITY ED	8/18/2023	\$25.00
Unposted	XCEL ENERGY	8/18/2023	\$541.66
Unposted	XCEL ENERGY-NSP	8/18/2023	\$1,218.72
Unposted	ZARNOTH BRUSH WORKS, INC	8/18/2023	\$925.60
	Total Checks		\$403,364.71

Fund Summary

	10150 Cash
101 General Fund	\$59,285.05
201 Fire Fund	\$3,125.47
202 Ambulance Fund	\$2,592.84
203 Community Center Fund	\$3,960.00
401 Capital Equipment Fund	\$24,564.75
601 Water Fund	\$7,469.76
603 AGI Sewer Fund	\$11,442.56
604 Electric Fund	\$290,924.28
	<u>\$403,364.71</u>

Payments

Current Period: AUGUST 2023

Payments Batch 08-21-23 PAY \$403,364.71

Refer	15555 BORDER STATES ELECTRIC				
Cash Payment Invoice	E 604-49550-635	Transformers,Wire,Pole	ADD'L 3-PHASE ELEC METERS (2nd SHPMNT)		\$5,863.12
Transaction Date	8/17/2023	Cash	10150	Total	\$5,863.12
Refer	15556 BOUND TREE MEDICAL, LLC				
Cash Payment Invoice	E 202-42153-217	Other Operating Supplie	JULY- AMB. SUPPLIES		\$180.66
Transaction Date	8/17/2023	Cash	10150	Total	\$180.66
Refer	15557 CEDA				
Cash Payment Invoice	E 101-41910-300	Professional Srvs	3rd QTR- P&Z / ECON. DEV. SERVICES		\$7,975.38
Cash Payment Invoice	E 101-46500-300	Professional Srvs	3rd QTR- P&Z / ECON. DEV. SERVICES		\$1,993.85
Transaction Date	8/17/2023	Cash	10150	Total	\$9,969.23
Refer	15558 FERGUSON WATERWORKS				
Cash Payment Invoice	E 601-49400-394	Meters, Hydrants, Paint	JULY- WATER METERS		\$3,619.76
Transaction Date	8/17/2023	Cash	10150	Total	\$3,619.76
Refer	15559 FILLMEUP				
Cash Payment Invoice	E 101-42110-480	Gas & Repair-Police Car	JULY- FUEL		\$898.76
Cash Payment Invoice	E 101-43000-485	Gas and Repair Miscella	JULY- FUEL		\$403.58
Cash Payment Invoice	E 202-42153-485	Gas and Repair Miscella	JULY- FUEL		\$186.42
Cash Payment Invoice	E 603-49450-485	Gas and Repair Miscella	JULY- FUEL		\$32.90
Transaction Date	8/17/2023	Cash	10150	Total	\$1,521.66
Refer	15560 FRITZS TINT SHOP				
Cash Payment Invoice	E 101-41400-218	Office Expense	CITY OFFICES WINDOW TINT		\$480.00
Transaction Date	8/17/2023	Cash	10150	Total	\$480.00
Refer	15561 IMPRINTS LABEL & DECAL				
Cash Payment Invoice	E 101-42110-210	Operating Supplies	NEW GOLF CART PERMIT STICKERS		\$315.00
Transaction Date	8/17/2023	Cash	10150	Total	\$315.00
Refer	15562 JERRY S HOME QUALITY FOODS				
Cash Payment Invoice	E 101-42110-200	Office Supplies	JULY- SUPPLIES & ANO ITEMS		\$28.92
Cash Payment Invoice	E 101-42110-731	Arlington Night Out	JULY- SUPPLIES & ANO ITEMS		\$181.46
Cash Payment Invoice	E 201-42280-208	Training and Instruction	JULY- SUPPLIES & ANO ITEMS		\$15.97
Cash Payment Invoice	E 202-42153-217	Other Operating Supplie	JULY- SUPPLIES & ANO ITEMS		\$30.93
Transaction Date	8/17/2023	Cash	10150	Total	\$257.28
Refer	15563 KURT MENK				

Payments

Current Period: AUGUST 2023

Cash Payment Invoice	E 101-45202-220	Repair/Maint Supply	REPLACEMENT PARK SWING INFANT SEAT		\$120.00
Transaction Date	8/17/2023		Cash	10150	Total \$120.00
Refer	15570 MINI BIFF, LLC				
Cash Payment Invoice	E 101-45202-418	Other Rentals	JULY- PARK TOILETS		\$818.04
Transaction Date	8/17/2023		Cash	10150	Total \$818.04
Refer	15571 MN MUNI. POWER AGENCY				
Cash Payment Invoice	E 604-49550-389	Electric Energy Purchas	JULY- ENERGY		\$232,394.83
Transaction Date	8/17/2023		Cash	10150	Total \$232,394.83
Refer	15572 MORRIS ELECTRONICS				
Cash Payment Invoice	E 101-41400-503	Computers/Software/We	JULY- OFFICE/PD IT WORK & CONTRACTS		\$971.10
Cash Payment Invoice	E 101-41400-503	Computers/Software/We	JULY- OFFICE/PD IT WORK & CONTRACTS		\$600.00
Cash Payment Invoice	E 101-42110-503	Computers/Software/We	JULY- OFFICE/PD IT WORK & CONTRACTS		\$828.60
Cash Payment Invoice	E 101-42110-503	Computers/Software/We	JULY- OFFICE/PD IT WORK & CONTRACTS		\$800.00
Transaction Date	8/17/2023		Cash	10150	Total \$3,199.70
Refer	15573 PEARSON BROS. INC.				
Cash Payment Invoice	E 401-43000-500	Capital Outlay	2023 SEALCOATING		\$24,564.75
Transaction Date	8/17/2023		Cash	10150	Total \$24,564.75
Refer	15574 PREMIER LOCATING, INC.				
Cash Payment Invoice	E 604-49550-637	Service Locations	JULY- ELEC LOCATING		\$2,722.00
Transaction Date	8/17/2023		Cash	10150	Total \$2,722.00
Refer	15575 SIBLEY COUNTY ASSESSOR				
Cash Payment Invoice	E 101-41550-300	Professional Svcs	2023 ASSESSOR SERVICES CONTRACT		\$10,940.00
Transaction Date	8/17/2023		Cash	10150	Total \$10,940.00
Refer	15576 SIBLEY EAST				
Cash Payment Invoice	E 101-41400-733	Reimbursible Expense	PRO-RATED FITNESS CTR FEE (AMB-S.F.)		\$25.00
Transaction Date	8/17/2023		Cash	10150	Total \$25.00
Refer	15577 XCEL ENERGY				
Cash Payment Invoice	E 603-49450-381	Electric & Heat Utilities	JULY- GRN ISLE LIFT STATION ELEC BILL		\$541.66
Transaction Date	8/17/2023		Cash	10150	Total \$541.66
Refer	15578 XCEL ENERGY-NSP				
Cash Payment Invoice	E 604-49550-397	Facility Charge	JULY- SUBSTATION FACILITY CHARGE		\$1,218.72
Transaction Date	8/17/2023		Cash	10150	Total \$1,218.72
Refer	15579 ZARNOTH BRUSH WORKS, INC				
Cash Payment Invoice	E 101-43000-485	Gas and Repair Miscella	STREET SWEEPER BROOMS		\$925.60



**CITY COUNCIL MEETING MINUTES
AUGUST 7, 2023, AT 6:30 PM
COUNCIL CHAMBERS**

The City Council is provided background information for agenda items in advance by city staff, committees, and boards. Many decisions regarding agenda items are based upon this information, as well as: City policy and practices, input from constituents, questions or information that has not yet been presented or discussed regarding an agenda item. If you have a concern or question, please ask to be recognized by the mayor during the "Citizens addressing the Council" portion of the agenda.

1. Call Meeting to Order and Pledge of Allegiance- *Meeting was called to order at 6:30pm by Mayor Scharpe. All stood for the Pledge of Allegiance.*

2. Roll Call

Members Present- Mayor Matthew Scharpe, Councilmembers John Thomes, Dave Meyer, Christina Litfin, Curtis Ling, Jeff Matz

Staff Present- City Administrator Jessica Steinke, City Attorney Ken Janssen

Guests Present- Kurt Menk Arlington Enterprise, Jake Pichelmann Bolton & Menk

3. Approval of the Agenda- *Thomes made a motion to approve the agenda. Litfin seconded. Motion carried all voting in favor.*

4. Citizens Addressing the Council

State your name and address for the record. Please keep comments under 5 minutes. Individuals wishing to speak for more than five minutes should ask to be included on the agenda in advance. All comments are appreciated, but please refrain from personal or derogatory attacks on individuals.

CONSENT AGENDA

5. Approval of Consent Agenda

A) Approval of Bills

B) July 17th, 2023, City Council Meeting Minutes

C) Approval of Liquor License for A-Town Tavern-On-Sale and Sunday

D) Approve the hiring of new firefighter, Jose Sandoval

E) Approve Drone Permit for Josia Velner & Luis Osorio

Meyer made a motion to approve the consent agenda. Matz seconded. Motion carried all voting in favor.

OLD BUSINESS

6. WTP Rehab Update, Jake Pichelmann Bolton & Menk- *Pichelmann gave an update on the WTP. Contractor and electrician are working to finish up.*

7. 2024 Street Project, Grant Eligibility, Jessica Steinke- *Steinke stated that the City is not eligible for grants for the street project. The Council discussed and decided to hold a workshop on Tuesday, September 5th before the Council meeting at 5:30pm.*



8. Discuss THC Moratorium Expiring 9/19/23- *Janssen advised to let the moratorium expire. Ling made a motion to let the moratorium expire. Thomes seconded. Motion carried with all voting in favor.*

NEW BUSINESS

9. Tax Forfeitures in Arlington, Christian Lilienthal- *tabled until next meeting.*
10. RESOLUTION 28-2023- A RESOLUTION ACCEPTING A DONATION AND DESIGNATING ITS USE
Ling made a motion to approve Resolution 28-2023. Meyer seconded. Motion carried. Matz, Thomes, Meyer, Ling, Litfin voted in favor. None against. None abstained. None were absent.
11. RESOLUTION 29-2023 – A RESOLUTION AMENDING THE CITY OF ARLINGTON 2023 COMPENSATION PLAN
Meyer made a motion to approve Resolution 29-2023, Thomes seconded. Motion carried. Ling, Litfin, Meyer, Thomes, Matz voted in favor. None against. None abstained. None were absent.
12. Golf Cart/LSV Laws-Police Chief Gerads gave an update on current state statutes and gave options for the city to adopt an ordinance allowing golf carts and LSV's.

REPORTS OF OFFICERS, BOARDS AND COMMITTEES

13. Submitted Fire Department report, Chief Mackenthun- *Report was submitted.*
14. City Administrator Update, Jessica Steinke- *Steinke reported that she is currently working on the budget. She thanked everyone that came out and the volunteers that were at the Arlington Night Out event.*
15. City Attorney Update, Ken Janssen-*Janssen reported that his office is working on putting the paperwork together for the AJH property for the EDA meeting.*

MISCELLANEOUS BUSINESS

ADJOURNMENT

Thomes made a motion to adjourn the meeting at 7:12 pm. Litfin seconded. Motion carried all voting in favor.

City Administrator Jessica Steinke

Mayor Matthew Scharpe

CHAPTER 7

MOTORIZED GOLF CARTS

SECTION:

- 7.07.1: Definitions
- 7.07.2: Motorized Golf Carts
- 7.07.3: Permitting
- 7.07.4: Fees
- 7.07.5: Unlawful Acts
- 7.07.6: Penalty

7.07.1 DEFINITIONS: For the purposes of this chapter, the terms defined herein shall have the meaning as follows:

MOTORIZED GOLF CART

Motorized golf cart means a vehicle, usually driven with three or four smooth, low-pressure tires, which is self-propelled and is designed to be used to provide transportation on a golf course for not more than four (4) persons in a seated position, that is powered by a limited gas or electrical engine displacement of less than 800 cubic centimeters, and total dry weight less than 800 pounds.

7.07.2 : MOTORIZED GOLF CARTS:

- A. Operation: The following operating restrictions shall apply to the operation of Motorized Golf Carts:
1. Single File, Right Hand Lane on designated Public Roads: No person shall operate a motorized golf cart on the portion of any right of way of any public road, except single file, on the most right-hand lane when available for traffic or as close as practical to the right-hand curb or edge of the roadway, except when passing another vehicle stopped in that lane.
 2. Private Property: No person shall operate a motorized golf cart on the private property of another, private business property, and private parking lots, without lawful authority or consent of the owner.
 3. Sidewalks And Paved Walkways: No person shall operate a motorized golf cart on public sidewalks, pedestrian paths, or paved trails within the City. Privately owned sidewalks, paths, and trails are not to be included in this definition.
 4. Times of Operation. No person shall operate a motorized golf cart on designated Public Roads between sunset and sunrise without rear-facing brake lights, taillights, turn signals, and headlights. No motorized golf cart shall be operated in inclement weather, except during emergency conditions, or when visibility is impaired by weather, smoke, fog, or other conditions, or at any time when there is insufficient visibility to clearly see persons and vehicles on the roadway at a distance of 500 feet.

5. Stop And Yield Intersections: Motorized golf carts may cross any street or highway intersecting a designated highway. The operator shall follow vehicle traffic laws in all circumstances.
 6. Motorized Golf Carts not equipped with brake lights or turn signals must use appropriate hand signals to signal turns as defined by Minnesota State Statute 169.19 Subd. 8.
 7. Persons at least sixteen (16) years of age and holding a valid driver's license recognized by the State of Minnesota as permitting the operation of motor vehicles in the state are allowed to operate a motorized golf cart on designated Public Roads within the City of Arlington.
 8. Insurance: Motorized Golf Cart must have current liability vehicle insurance that complies with the provisions of Minnesota Statutes Section 65B.48 subdivision. 5, or its successors.
 9. Motorized golfs carts shall only be operated on City owned designated streets and alleys within the boundaries of the City with the following exception:
 - a. Motorized golfs carts may cross any county or state highway intersecting a City owned street, but only for the purposes of crossing.
 - b. Motorized golf carts are prohibited from traveling on roadways where the speed limit is posted in excess of 30 mph.
 - c. Motorized golf carts are prohibited from driving on Minnesota State Highway 5.
 10. The operation of a motorized golf cart on any city streets may only be done with a city-issued permit.
 11. The number of occupants of the motorized golf cart may not exceed the design occupant load.
- B. Operation Prohibited in City Parks: It shall be illegal to operate a motorized golf cart within the boundaries of a City designated park, except for the use of and within the parking lot.
- C. Required Equipment: Motorized Golfs Carts shall have the following required equipment:
1. Brakes: Brakes adequate to control the movement of and to stop and hold the motorized golf cart.
 2. Mufflers: Gas motorized golf cart: Standard mufflers which are properly attached and in constant operation and which reduce the noise of operation of the motor to the minimum necessary for operation. No person shall use a muffler cutout, bypass, straight pipe or similar device on a gas motorized golf car, and the exhaust system shall not emit or produce a sharp popping or crackling sound.
 3. Rearview Mirror: The motorized golf cart shall be equipped with a rearview mirror so located as to reflect to the driver, operator, or controller, a view of the roadway for a distance of at least 200 feet to the rear of such vehicle, in compliance with Minnesota Statue Section 169.70, or its predecessors.
 4. Slowing Moving Vehicle Sign: The motorized golf cart shall be equipped with a slow- moving vehicle sign on the rear of the vehicle in compliance with Minnesota Statutes Section 169.522. The emblem must consist of a fluorescent or illuminated red-orange triangle with a dark red reflective boarder and be mounted so as to be visible from a distance of not less than 600 feet to the rear.
 5. Permit: The City of Arlington permit for operating a motorized golf cart must be visible from the rear-view of the golf cart at all times.

7.07.3: PERMITTING:

- D. Permits: No motorized golf cart shall be driven, operated, or controlled on the roadways or shoulders of roadways under the jurisdiction of the City of Arlington, unless the driver or operator has in his or her actual physical possession a valid, current and un-revoked permit from the City of Arlington for such driving or operation of a motorized golf cart.
- E. Permit Issuance: Permits shall be issued by the Police Department, or authorized designee, upon compliance with this section.
 - a. No person whose driver's license is revoked, suspended, canceled, or withdrawn as a result of criminal proceedings may be issued an individual permit. Any restrictions on the use of the motor vehicle driver's license shall apply to the permit provided for under this ordinance.
 - b. *Application.* An individual permit application shall include the following:
 - i. Full name and address of the applicant;
 - ii. Model name, make and year and number of motorized golf cart.
 - iii. Current valid driver's license information, including State where the driver's license was issued and driver's license number, or the reason for not having a valid driver's license;
 - iv. The date of application and applicant's signature;
 - v. Proof of Insurance and the name of applicant's insurance company as provided for in Minnesota Statutes Section 65B.48 subdivision 5. The proof of insurance must show that the golf cart is covered by the applicant's insurance policy; to include the number of the applicant's insurance policy; and the date of expiration of insurance coverage for such vehicle.
 - c. *Expiration and Renewal.* Permits shall be effective on January 1st of the issuing year and are valid for three (3) years to expire on December 31st of the third year. The renewal is the responsibility of the owner, and no notification will be sent to the owner on the expiration of the permit. The term will be noted on the permit application and a copy provided to the applicant. Ex: Permit issued for 2024 will expire December 31st, 2026. Permit to be visibly displayed on the rear of the golf cart and may not be obstructed.
 - d. *Revocations or Non-Renewal.* An individual permit may be revoked by the Police Department, or designee under the following circumstances:
 - i. If there is found that there was any misrepresentation made in the permit application;
 - ii. There is a cancellation, non-renewal, or termination of the liability insurance for the golf cart; or
 - iii. The permit holder is found to be in violation of any provision of this Chapter on two separate occasions during the calendar year.
 - iv. A permit may be revoked at any time if there is evidence that the permittee cannot safely operate the motorized golf cart on the designated roadways.

The Chief of Police, or designee shall issue a notice of revocation or non-renewal of a permit to the permit holder in writing and either hand deliver the notice to the permit holder or send the notice by certified mail to the permit holder at the address provided on the application. The permit holder shall have 10 days to appeal the revocation or non-renewal to the City Attorney's Office through the administrative civil penalties' proceedings, otherwise the revocation or non-renewal shall be effective. Said notice of appeal shall be in writing and filed with the Chief of Police, or designee.

7.07.4: FEES.

- F. An individual shall pay a fee as determined by the annual fee schedule at the time an application is submitted.

7.07.5: UNLAWFUL ACTS.

- G. No motorized golf cart shall be driven, operated, or controlled on the roadways or shoulders of roadways under the jurisdiction of the City of Arlington, if it is in violation of any portion of this ordinance or as follows:
 - a. Contrary to any Arlington City Code or the traffic code of the State of Minnesota;
 - b. Without a current valid driver's license;
 - c. With a number of passengers that exceeds the number of passengers in which the golf cart was designed for.
- H. Every person operating a motorized golf cart has all the rights and duties applicable to the driver of any other vehicle under the provisions of Minnesota Statute Chapter 169, as it may be amended from time to time, except when these provisions cannot reasonably be applied to motorized golf carts and except as otherwise specifically provided in Minnesota Statute Section 169.045, Subd. 7, as it may be amended from time to time.
- I. No motorized golf carts shall be driven on Minnesota State Highway 5 unless to immediately and directly cross-over Minnesota State Highway 5.

7.07.6: PENALTY.

- J. Any person violating any provisions of this ordinance shall be guilty of a petty misdemeanor and upon conviction thereof shall be punished by a fine as determined by the adopted city administrative fee schedule.

2.75 in

**CITY OF
ARLINGTON**

001

**GOLF CART
PERMIT
EXPIRES 12-31-2026**

2.75 in



Arlington Police Department

Glenn Gerads, Chief of Police

108 4th Ave. NW, Arlington, MN 55307
Office: (507)964-5200 Fax: (507)964-2737
E-mail: police@arlingtonmn.gov

APPLICATION FOR GOLF CART OR ATV PERMIT

CITY OF ARLINGTON

NAME: _____

ADDRESS: _____

TELEPHONE: _____

DRIVER'S LICENSE#: _____

INSURANCE POLICY: _____ (Copy of insurance card required)

ATTACHED PHYSICIAN'S NOTE (Physically able to operate a golf cart or ATV if on a canceled DL)

INTENDED AREAS OF USE WITHIN THE CITY OF ARLINGTON: _____

SIGNATURE: _____

DATE: _____

FOR OFFICE USE ONLY

APPROVED **REASON:** _____

TERM OF PERMIT: _____ **PERMIT#:** _____

DENIED **REASON:** _____

Regulating Special Vehicles, LMC Model Ordinance

League models are thoughtfully developed by our staff for a city's consideration. Models should be customized as appropriate for an individual city's circumstances in consultation with the city's attorney. Helpful background information on this model may be found in ["Special Vehicles Operating on City Streets."](#)

ORDINANCE NO. _____

AN ORDINANCE REGULATING SPECIAL VEHICLES.

The City Council of _____, Minnesota ordains:

§ 1. SPECIAL VEHICLES: MOTORIZED GOLF CARTS, UTILITY TASK VEHICLES, CLASS 1 ALL-TERRAIN VEHICLES, AND MINI-TRUCKS.

(A) (1) No person shall operate a motorized golf cart, utility task vehicle, all-terrain vehicle, or mini-truck on streets, alleys, sidewalks or other public property without obtaining a permit as provided herein.

(2) Every application for a permit shall be made on a form supplied by the city and shall contain all of the following information:

- (a) The name and address of the applicant.
- (b) The nature of the applicant's physical handicap, if any.
- (c) Model name, make, and year and number of the motorized golf cart, all-terrain vehicle, or mini-truck.
- (d) Current driver's license or reason for not having a current license.
- (e) Other information as the city may require.

(3) The permit fee shall be as set forth in the Ordinance Establishing Fees and Charges adopted pursuant to § _____ of this code, as that ordinance may be amended from time to time.

(4) Permits shall be granted for a period of _____ [up to three years] and may be renewed.

(5) No permit shall be granted or renewed unless the following conditions are met:

(a) The applicant must demonstrate that he or she currently holds or has held a valid Minnesota driver's license to operate a mini-truck.

(b) The applicant may be required to submit a certificate signed by a physician that the applicant is able to safely operate a motorized golf cart, utility task vehicle or all-terrain vehicle on the roadways designated.

(c) The applicant must provide evidence of insurance in compliance with the provisions of Minnesota Statutes concerning insurance coverage for the golf cart, utility task vehicle, all-terrain vehicle, or mini-truck.

(d) The applicant has not had his or her driver's license revoked as the result of criminal proceedings.

(6) Motorized golf carts, utility task vehicles, all-terrain vehicles, and mini-trucks are permitted to operate only on city streets, not state or federal highways, except to cross at designated intersections.

(7) Motorized golf carts, utility task vehicles and all-terrain vehicles may only be operated on designated roadways from sunrise to sunset. They shall not be operated in inclement weather conditions or at any time when there is insufficient light to clearly see persons and vehicles on the roadway at a distance of 500 feet.

(8) Motorized golf carts shall display the slow-moving vehicle emblem provided for in Minn. Stat. § 169.045, as it may be amended from time to time, when operated on designated roadways.

(9) Motorized golf carts, utility task vehicles, all-terrain vehicles, and mini-trucks shall be equipped with a rear-view mirror to provide the driver with adequate vision from behind as required by Minn. Stat. § 169.70.

(10) The operator of a motorized golf cart, utility task vehicle, all-terrain vehicle, or mini-truck may cross any street or highway intersecting a designated roadway.

(11) Every person operating a motorized golf cart, a utility task vehicle, an all-terrain vehicle, or a mini-truck under permit on designated roadways has all the rights and duties applicable to the driver of any other vehicle under the provisions of Minn. Stat. ch. 169, as it may be amended from time to time, except when these provisions cannot reasonably be applied to motorized golf carts or mini-trucks and except as otherwise specifically provided in Minn. Stat. § 169.045, subd.7, as it may be amended from time to time.

(12) The City Council may suspend or revoke a permit granted hereunder upon a finding that the holder thereof has violated any of the provisions of this section or Minn. Stat. ch. 169, as it may be amended from time to time, or if there is evidence that the permit holder cannot safely operate the motorized golf cart, utility task vehicle, all-terrain vehicle, or mini-truck on the designated roadways.

(13) The number of occupants on the golf cart, utility task vehicle, all-terrain vehicle, or mini-truck may not exceed the design occupant load.

(B) For the purpose of this section, the following definitions shall apply unless the context clearly indicates or requires a different meaning.

DRIVER. The person driving and having physical control over the motorized golf cart, utility task vehicle, all-terrain vehicle, or mini-truck and being the licensee.

MOTORIZED GOLF CART. Any passenger conveyance being driven with four wheels with four low-pressure tires that is limited in engine displacement of less than 800 cubic centimeters and total dry weight less than 800 pounds.

UTILITY TASK VEHICLE. As defined by Minn. Stat. § 169.045, subd. 1 (3), a side-by-side, four-wheel drive, off-road vehicle that has four wheels, is propelled by an internal combustion engine with a piston displacement capacity of 1,200 cubic centimeters or less, and has a total dry weight of 1,800 but less than 2,600 pounds.

MINI-TRUCK. As defined in Minn. Stat. § 169.011, subd. 40(a), a motor vehicle that has four wheels; is propelled by an electric motor with a rated power of 7,500 watts or less or an internal combustion engine with a piston displacement capacity of 660 cubic centimeters or less; has a total dry weight of 900 to 2,200 pounds; contains an enclosed cabin and a seat for the vehicle operator; commonly resembles a pickup truck or van, including a cargo area or bed located at the rear of the vehicle; and was not originally manufactured to meet federal motor vehicle safety standards required of motor vehicles in the Code of Federal Regulations, title 49, sections 571.101 to 571.404, and successor requirements. A mini-truck does not include: a neighborhood electric vehicle or a medium-speed electric vehicle; or a motor vehicle that meets or exceeds the regulations in the Code of Federal Regulations, title 49, section 571.500, as it may be amended from time to time.

(C) Authorized city staff may operate city owned motorized golf carts and mini-trucks without obtaining a permit within the city on city streets, sidewalks, trails, rights-of-way, and public property when conducting city business.

(D) Mini-truck equipment requirements:

(1) A mini-truck may be operated under permit on designated roadways if it is equipped with all of the following:

- (a) At least two headlamps.
- (b) At least two tail lamps.
- (c) Front and rear turn-signal lamps.
- (d) An exterior mirror mounted on the driver's side of the vehicle and either an exterior mirror mounted on the passenger's side of the vehicle or an interior mirror.
- (e) A windshield.
- (f) A seat belt for the driver and front passenger.
- (g) A parking brake.

§ 2. OPERATION OF ELECTRIC PERSONAL ASSISTIVE MOBILITY DEVICES.

(A) **ELECTRIC PERSONAL ASSISTIVE MOBILITY DEVICE** means a self-balancing device with two non-tandem wheels, designed to transport not more than one person, and operated by an electric propulsion system that limits the maximum speed of the device to 15 miles per hour.

(B) Except as otherwise provided by law, a person operating an electric personal assistive mobility device has the rights and responsibilities of a pedestrian.

(C) *Operation.*

(1) An electric personal assistive mobility device may be operated on a bicycle path.

(2) No person may operate an electric personal assistive mobility device on a roadway, sidewalk, or bicycle path at a rate of speed that is not reasonable and prudent under the conditions. Every person operating an electric personal assistive mobility device on a roadway, sidewalk, or bicycle path is responsible for becoming and remaining aware of the actual and potential hazards then existing on the roadway or sidewalk and must use due care in operating the device.

(3) An electric personal assistive mobility device may be operated on a roadway only under the following circumstances:

(a) While making a direct crossing of a roadway in a marked or unmarked crosswalk.

(b) Where no sidewalk is available.

(c) Where a sidewalk is so obstructed as to prevent safe use.

(d) When so directed by a traffic control device or by a peace officer.

(e) Temporarily in order to gain access to a motor vehicle.

(f) As provided in division (7) below by Council resolution.

(4) An electric personal assistive mobility device may not be operated at any time on a roadway with a speed limit of more than 35 miles per hour except to make a direct crossing of the roadway in a marked crosswalk.

(5) An electric personal assistive mobility device may not be operated at any time while carrying more than one person.

(6) Designated exclusive city streets. The City Council may, by resolution, designate exclusive city streets within its jurisdiction where the operation of electric personal assistive mobility devices is not permitted, provided that any street so designated has a speed limit of more than 35 miles per hour.

(7) A person operating an electric personal assistive mobility device on a sidewalk must yield the right-of-way to pedestrians at all times. A person operating an electric personal assistive mobility device on a bicycle path must yield the right-of-way to bicycles at all times.

(8) An electric personal assistive mobility device may not be operated unless the device bears reflectorized material on the front, back, and wheels, visible at night from 600 feet when illuminated by the lower beams of headlamps of a motor vehicle.

§ 3. MOTORIZED FOOT SCOOTERS

(A) **MOTORIZED FOOT SCOOTER** means a device with handlebars designed to be stood or sat upon by the operator, and powered by an internal combustion engine or electric motor that is capable of propelling the device with or without human propulsion, and that has no more than two 12-inch or smaller diameter wheels and has an engine or motor that is capable of a maximum speed of 15 miles per hour on a flat surface with not more than 1 percent grade in any direction when the motor is engaged. An electric personal assistive mobility device, a motorized bicycle, an electric-assisted bicycle, or a motorcycle is not a motorized foot scooter.

(B) Operation of a motorized foot scooter on city bicycle paths, bicycle lanes, bicycle trails, or bikeways is prohibited except as provided in division (C) below.

(C) The City Council may, by resolution, designate specific bicycle paths, bicycle lanes, bicycle trails, or bikeways as available for use by motorized foot scooters.

(D) Every person operating a motorized foot scooter shall have all rights and duties applicable to the operator of a bicycle, except in respect to those provisions relating expressly to motorized foot scooters and in respect to those provisions of law that by their nature cannot reasonably be applied to motorized foot scooters.

(E) No person may operate a motorized foot scooter upon a sidewalk, except when necessary to enter or leave adjacent property. No person may operate a motorized foot scooter that is carrying any person other than the operator.

(F) No person under the age of 12 years may operate a motorized foot scooter.

(G) No person under the age of 18 years may operate a motorized foot scooter without wearing properly fitted and fastened protective headgear that complies with standards established by the commissioner of Public Safety.

(H) A motorized foot scooter must be equipped with a headlight and a taillight that comply with standards established by the commissioner of Public Safety if the vehicle is operated under conditions when vehicle lights are required by law.

(I) A person operating a motorized foot scooter on a roadway shall ride as close as practicable to the right-hand curb or edge of the roadway, except in the following situations:

(1) When overtaking and passing another vehicle proceeding in the same direction.

(2) When preparing for a left turn, in which case the operator shall stop and dismount at the right-hand curb or right edge of the roadway, and shall complete the turn by crossing the roadway on foot, subject to restrictions placed by law on pedestrians.

(3) When reasonably necessary to avoid impediments or conditions that make it unsafe to continue along the right-hand curb or edge, including, but not limited to, fixed or moving objects, vehicles, bicycles, pedestrians, animals, surface hazards, or narrow lanes.

§ 4. MEDIUM-SPEED ELECTRIC VEHICLES AND NEIGHBORHOOD ELECTRIC VEHICLES

(A) Definitions.

(1) ***MEDIUM SPEED ELECTRIC VEHICLE*** means an electrically powered four-wheeled motor vehicle, equipped with a roll cage or crushproof body design, that can attain a maximum speed of 35 miles per hour on a paved level surface, is fully enclosed and has at least one door for entry, has a wheelbase of 40 inches or greater and a wheel diameter of 10 inches or greater, and except with respect to maximum speed, otherwise meets or exceeds regulations in the Code of Federal Regulations, title 49, section 571.500, and successor requirements.

(2) **NEIGHBORHOOD ELECTRIC VEHICLE** means an electrically powered motor vehicle that has three or four wheels, and has a speed attainable in one mile of at least 20 miles per hour, but not more than 25 miles per hour on a paved level surface.

(B) Operation of neighborhood electric vehicles on city streets is prohibited except as provided in (C) below.

(C) Use on designated exclusive city streets. The City Council may, by resolution, designate exclusive city streets within its jurisdiction where the operation of neighborhood electric vehicles or medium-speed electric vehicles is permissible, provided that no street so designated has a speed limit of more than 35 miles per hour.

(D) A neighborhood electric vehicle or a medium-speed electric vehicle may be operated on public streets and highways only if it meets all equipment and vehicle safety requirements in Code of Federal Regulations, title 49, section 571.500, as it may be amended from time to time.

(E) Authorized city staff may operate city owned neighborhood electric vehicles and medium-speed electric vehicles within the city on city streets, sidewalks, trails, rights-of-way, and public property when conducting city business.

Passed by the City Council of _____, Minnesota this _____ day of Month, Year.

Mayor

Attested:

City Clerk

COUNTY OF SIBLEY

ORDINANCE No.: _____

**ORDINANCE REGULATING THE USE OF CANNABIS AND
CANNABIS DERIVED PRODUCTS IN PUBLIC PLACES**

THE SIBLEY COUNTY BOARD OF COMMISSIONERS HEREBY ORDAINS
AS FOLLOWS:

SECTION 1. PURPOSE AND INTENT

This Ordinance is adopted by Sibley County for the purpose of protecting public health and safety by REGULATING/PROHIBITING the use of Cannabis and cannabis derived products in public places and places of public accommodation within Sibley County.

Minnesota Session Law 2023, Chapter 63, effective in relevant part August 1, 2023, establishes that the adult use, possession and personal growing of cannabis is legal subject to the requirements and restrictions of Minnesota Statutes.

Minnesota Session Law 2023, Chapter 63, Art. 4, section 19, codified as Minn. Stat. 342.0263, subd. 5 authorizes the adoption of a local ordinance establishing a petty misdemeanor offense for public use of cannabis.

The County intends to be proactive in protecting public health and safety by enacting an ordinance that will mitigate threats presented to the public and public health by the public use of cannabis.

Sibley County (hereinafter “the County”) recognizes the risks that unintended access and use of cannabis products and exposure to cannabis and its effects present to the health, welfare, and safety of members of the public and in particular the youth of the County.

SECTION 2. DEFINITIONS

Except as may otherwise be provided or clearly implied by context, all terms shall be given their commonly accepted definitions. The following words, terms, and phrases, when used in this ordinance, shall have the meanings ascribed to them except where the context clearly indicates a different meaning.

(a) **Adult-use cannabis flower.** “Adult-use cannabis flower” means cannabis flower that is approved for sale by the Minnesota Office of Cannabis Management or is substantially similar to a product approved by the office. Adult-use cannabis flower does not include medical cannabis flower, hemp plant parts, or hemp-derived consumer products.

(b) **Adult-use cannabis products.** “Adult-use cannabis products” means a cannabis product that is approved for sale by the office or is substantially similar to a product approved by the office. Adult-use cannabis product includes edible cannabis products but does not include medical cannabinoid products or lower-potency hemp edibles.

(c) **Cannabis flower.** “Cannabis flower” means the harvested flower, bud, leaves, and stems of a cannabis plant. Cannabis flower includes adult-use cannabis flower and medical cannabis flower. Cannabis flower does not include cannabis seed, hemp plant parts, or hemp-derived consumer products.

(d) **Cannabis product.** “Cannabis product” means any of the following:

- (1) cannabis concentrate;
- (2) a product infused with cannabinoids, including but not limited to tetrahydrocannabinol, extracted or derived from cannabis plants or cannabis flower; or
- (3) any other product that contains cannabis concentrate.

(e) **Hemp derived consumer products.**

(1) “Hemp derived consumer products” means a product intended for human or animal consumption, does not contain cannabis flower or cannabis concentrate, and:

- (i) contains or consists of hemp plant parts; or
- (ii) contains hemp concentrate or artificially derived cannabinoids in combination with other ingredients.

(2) Hemp-derived consumer products does not include artificially derived cannabinoids, lower-potency hemp edibles, hemp-derived topical products, hemp fiber products, or hemp grain.

(f) **Lower-potency hemp edible.** A “lower-potency hemp edible” means any product that:

- (1) is intended to be eaten or consumed as a beverage by humans;
- (2) contains hemp concentrate or an artificially derived cannabinoid; in combination with food ingredients;
- (3) is not a drug;
- (4) consists of servings that contain no more than five milligrams of delta-9 tetrahydrocannabinol, 25 milligrams of cannabitol, 25 milligrams of cannabitol, or any combination of those cannabinoids that does not exceed the identified amounts;
- (5) does not contain more than a combined total of 0.5 milligrams of all other cannabinoids per serving;
- (6) does not contain an artificially derived cannabinoid other than delta-9 tetrahydrocannabinol;
- (7) does not contain a cannabinoid derived from cannabis plants or cannabis flower; and
- (8) is a type of product approved for sale by the office or is

substantially similar to a product approved by the office, including but not limited to products that resemble nonalcoholic beverages, candy, and baked goods.

(g) **Public place.** A “public place” means a public park or trail, public street or sidewalk, any enclosed, indoor area used by the general public, including, but not limited to, theaters, restaurants, bars, food establishments, places licensed to sell intoxicating liquor, wine, or malt beverages, retail businesses, gyms, common areas in buildings, public shopping areas, auditoriums, arenas, or other places of public accommodation.

(h) **Place of public accommodation.** “Place of public accommodation” means a business, refreshment, entertainment, recreation, or transportation facility of any kind, whose goods, services, facilities, privileges, advantages, or accommodations are extended, offered, sold, or otherwise made available to the public.”

(i) **Exceptions to the definition of public place or place of public accommodation.** “A public place” or “a place of public accommodation” does not include the following:

- (1) a private residence, including the individual’s curtilage or yard.
- (2) a private property, not generally accessible by the public, unless the individual is explicitly prohibited from consuming cannabis flower, cannabis products, lower-potency hemp edibles, or hemp-derived consumer products on the property by the owner of the property; or
- (3) on the premises of an establishment or event licensed to permit on-site consumption.

(j) **Smoking.** “Smoking” means inhaling, exhaling, burning, or carrying any lighted or heated cigar, cigarette, pipe, or any other lighted or heated product containing cannabis flower, cannabis products, artificially derived cannabinoids, or hemp-derived consumer products. Smoking includes carrying or using an activated electronic delivery device for human consumption through inhalation of aerosol or vapor from the product.

SECTION 3. PROHIBITED ACTS

Subd. 1. No person shall use cannabis flower, cannabis products, lower-potency hemp edibles, or hemp- derived consumer products in a public place or a place of public accommodation unless the premises is an establishment or event licensed to permit on-site consumption of adult-use cannabis flower and adult use cannabis products. *See Minnesota Session Law 2023, Chpt. 63, Art. 1, Sec. 9 codified as Minn. Stat. 342.09, subd. 1(2) and 342.09, subd.1 (7)(iii) and Art. 4, Sec. 19 codified as Minn. Stat. Sec. 152.0263, subd. 5.*

Subd. 2. No person shall vaporize or smoke cannabis flower, cannabis products, artificially derived cannabinoids, or hemp-derived consumer products in any location where the smoke, aerosol, or vapor would be inhaled by a minor. *Minnesota Session Law 2023, Chpt. 63, Art. 1, Sec. 9 codified as Minn. Stat. Sec. 342.09, subd. 1 (7)(b)(9).*

SECTION 4. PENALTY

Subd. 1. Criminal Penalty. A violation of this ordinance shall be a petty misdemeanor punishable by a fine of up to \$300. Nothing in this ordinance shall prohibit the United States, the State of Minnesota, or the County from investigating or prosecuting any other activity that is a crime under any other federal or state statute or county ordinance.

Subd.2. An alleged violation or violation of this ordinance may be investigated by a peace officer as defined in Minn. Stat. 626.84, Subd. 1. Any alleged violation or violation of this ordinance shall be prosecuted by the Office of the Sibley County Attorney.

SECTION 5. SEVERABILITY

If any section or provision of this ordinance is held invalid, such invalidity will not affect any other section or provision that can be given force and effect without the invalidated section or provision.

SECTION 6. EFFECTIVE DATE

This ordinance shall be in full force and effect immediately from and after its passage and publication as required by law.

ADOPTED by the _____ County Board of Commissioners this _____ day of ____, 2023.

Sibley County Board Chair

Attest: _____
Sibley County Administrator



Councilmember _____ introduced the following resolution and moved for its adoption:

RESOLUTION 30-2023

A RESOLUTION AMENDING THE 2023 CITY CALENDAR

BE IT RESOLVED that the attached Calendar is hereby designated as the official City of Arlington Calendar of Public Meetings for the year 2023.

The motion for the adoption of the foregoing resolution was duly seconded by Councilmember _____; and upon poll being taken thereon the following voted in favor thereof: _____; the following voted against: _____; the following abstained: _____; and the following were absent: _____.

The foregoing resolution was adopted by the City Council of the City of Arlington this 21st day of August 2023.

Signed: _____
Mayor Matthew Scharpe

Attest: _____
City Administrator Jessica Steinke

Whereupon the resolution was declared duly passed and adopted and was signed by the Mayor whose signature was attested by the City Administrator.

CITY OF ARLINGTON

2023 PUBLIC MEETINGS

(MEETING DATES ARE SUBJECT TO CHANGE)

Holidays - City Offices Closed:

January 16th – Martin Luther King Jr. Day
 February 20th – Presidents’ Day
 May 29th – Memorial Day
 June 19th – Juneteenth (Federal Holiday not Observed)
 July 4th – Independence Day
 September 4th – Labor Day
 November 11th – Veterans Day
 November 23rd and 24th – Thanksgiving
 December 25th - Christmas

January	City Council	6:30PM	January 3
	Planning & Zoning	7:00PM	January 5
	EDA	5:30PM	January 9
	City Council	6:30PM	January 17
	Cemetery	6:00PM	January 23
	Parks	7:00PM	January 23
	Fire Relief (Fire Hall)	6:30PM	January 25
February	Emergency Operations (EMS bldg.)	5:30PM	February 2
	Planning & Zoning	7:00PM	February 2
	City Council	6:30PM	February 6
	EDA	5:30PM	February 13
	Event Center	5:30PM	February 9
	Township/Fire/Ambulance	7:00PM	February 9
	Library	5:30PM	February 15
	City Council	6:30PM	February 21
	Fire Relief (Fire Hall)	6:30PM	February 22
	• Fire Dept & Ambulance-1st Meeting	• Historical Society-2nd Meeting	
March	Planning & Zoning	7:00PM	March 2
	City Council	6:30PM	March 6
	EDA	5:30PM	March 13
	City Council	6:30PM	March 20
	Fire Relief (Fire Hall)	6:30PM	March 29
	• EDA & Planning & Zoning-1st Meeting	• Parks/Trails-2nd Meeting	
	City Council	6:30PM	April 3

	Planning & Zoning	7:00PM	April 6
	EDA	5:30PM	April 10
	A-GI Wastewater (Arlington)	7:00PM	April 13
	City Council	6:30PM	April 17
	Cemetery	6:00PM	April 24
	Parks	7:00PM	April 24
	Fire Relief	6:30PM	April 26
	• Electrical Engineer-1st Meeting	• PeopleService-2nd Meeting	

May	City Council	6:30PM	May 1
	Planning & Zoning	7:00PM	May 4
	EDA	5:30PM	May 8
	Event Center	5:30PM	May 11
	City Council	6:30PM	May 15
	Library (<i>Library</i>)	5:30PM	May 17
	Fire Relief	6:30PM	May 24
	• Library-1st Meeting	•	
June	Planning & Zoning	7:00PM	June 1
	City Council	6:30PM	June 5
	EDA	5:30PM	June 12
	City Council	6:30PM	June 19
	Fire Relief	6:30PM	June 28
	• Cemetery-1st Meeting		
July	City Council	7:00PM	July 3
	Planning & Zoning	7:00PM	July 6
	EDA	5:30PM	July 10
	City Council	6:30PM	July 17
	Cemetery	6:00PM	July 24
	Parks	7:00PM	July 24
	Fire Relief	6:30PM	July 26
August	Planning & Zoning	7:00PM	August 3
	City Council	6:30PM	August 7
	Event Center	5:30PM	August 10
	EDA	5:30PM	August 14
	City Council	6:30PM	August 21
	Library (<i>Library</i>)	5:30PM	August 16
	Fire Relief	6:30PM	August 30
	• Fire Relief-1st Meeting	6:30PM	
September	City Council	6:30PM	September 5
	Planning & Zoning (as needed)	7:00PM	September 7
	EDA	5:30PM	September 7
	City Council	6:30PM	September 18
	Township/Fire/Ambulance	7:00PM	September 27
	Fire Relief	6:30PM	September 27

	City Council	6:30PM	October 2
October	Planning & Zoning (as needed)	7:00PM	October 5
	EDA	5:30PM	October 5
	City Council	6:30PM	October 16
	Cemetery	6:00PM	October 23
	Parks	7:00PM	October 23
	Fire Relief	6:30PM	October 25
November	Planning & Zoning (as needed)	7:00PM	November 2
	EDA	5:30PM	November 2
	City Council	6:30PM	November 6
	Event Center	5:30PM	November 9
	Library (<i>Library</i>)	5:30PM	November 15
	City Council	6:30PM	November 20
	Fire Relief	6:30PM	November 29
December	City Council	6:30PM	December 4
	Planning & Zoning (as needed)	7:00PM	December 7
	EDA	5:30PM	December 7
	City Council	6:30PM	December 18
	Fire Relief	6:30PM	December 27

MEETING SCHEDULE:

- City Council 1st & 3rd Monday Evenings @ 6:30 pm
- EDA 1st Thursday Evening (Monthly) @ 5:30pm
- Planning & Zoning 1st Thursday Evening (Monthly) @ 7:00 pm
- A-GI Wastewater 2nd Thursday Evening April (ARL)/September (GI)@ 7:00 pm
- Library 3rd Wednesday Evening (Quarterly- 2nd mo.) @ 5:30 pm (Library)
- Park Board 4th Monday Evening (Quarterly- 1st mo.) @ 7:00 pm
- Township/Fire/Ambulance 2nd Thursday February/3rd Thursday September @7:00 pm (EMS Bldg)
- Fire Relief Last Wednesday Evening (Monthly) (Fire Hall)
- Event Center 2nd Thursday Evening (Quarterly- 2nd mo.) @ 5:30 pm
- Emergency Operation Plan 1st Wednesday in February (Annually) (EMS Bldg.)

**All meetings are at Community Center-Council Chambers unless otherwise noted.*

***All meeting dates are subject to change, plus additional (special) meetings could be scheduled.*

Annual Schedule for Committees to Report to City Council

(attended by a minimum of 2 representatives from each):

February:	• Fire Dept & Ambulance-1 st Meeting	• Historical Society-2 nd Meeting
March:	• EDA & P&Z - 1 st Meeting	• Parks/Trails-2 nd Meeting
April:	• Electrical Engineer-1 st Meeting	• PeopleService-2 nd Meeting
May:	• Library-1 st Meeting	_____
June:	_____	• Cemetery -2 nd Meeting
August:	• Fire Relief-1 st Meeting	_____

BARGEN INCORPORATED

606 County Road 1
Phone (507) 427-2924
Mountain Lake, MN 56159

August 3, 2023

City of Arlington
Attn: Kirby Weckworth
204 W. Shamrock Drive
Arlington, MN 55307

Kirby,

Thank you for the opportunity to explain the asphalt pavement maintenance services our firm offers and to provide you with a quote. I am confident that you will find the services beneficial for your roads. I would like to explain the procedures our service crew uses.

Maxwell Mastic Gap Level and Fill (widened crack repair)

The existing cracks will be cleaned of debris and/or moisture using a heat lance. We will then spray apply a tack coat. The Maxwell Mastic Gap is a revolutionary rubberized hot pour patching material designed to repair wide cracks, pot holes, rutting and depressed broken-up areas in asphalt and concrete pavement surfaces. It is also ideal for use around manholes, gutters and drains. When applied properly, Maxwell Mastic Gap creates a load bearing, weather resistant, durable bond resulting in a long term pavement maintenance solution.

Project Prices - Our price includes all materials, applicable taxes and labor to complete the project as explained.

Please note: The Customer is responsible for notifying the public that we will be working in your area. Pavement maintenance can be extremely dusty and dirty work and we strongly encourage the public to keep their personal property at a strong distance away from our work zone. This will avoid any possible concerns for dust, debris or damage. A recommended distance would be 75 – 150 feet away from the work zone. An Insurance Certificate is available upon request.

Gap Mastic Repairs

1. 7th Ave. west – 7 cracks per the map \$3,042.00
2. Adams Street west – 8 cracks per the map, 1 manhole & 1 water valve \$3,656.00
- ~~3. Dayton Street east – 7 cracks and 100 ft. on edges of street and end of driveways \$4,104.00~~
- ~~4. Creek View – 12 cracks and 100 ft. along edge of street and 1 manhole \$6,364.00~~

If all Gap is chosen to be completed, the price would be ~~\$17,166.00~~

\$6,698.00

M.R.

PAVING & EXCAVATING, INC.

2020 North Spring Street

P.O. Box 787

New Ulm, MN.56073

Phone (507) 354-4171

Fax (507) 359-4156

August 3, 2023

Kirby Weckworth
City of Arlington
204 Shamrock Drive
Arlington, MN 55307

Maxwell Mastic Gap (widened crack repair) Procedures:

The existing cracks will be cleaned of debris and/or moisture using a heat lance. We then spray apply Gap Primer. We will then fill the cracks with Gap Mastic. The Gap will be applied in two lifts, the first lift is a narrower application, and the second layer is wider and will level and smooth out the cracks. The Maxwell Mastic Gap is a revolutionary rubberized hot pour patching material designed to repair wide cracks, potholes, rutting and depressed broken-up areas in asphalt and concrete pavement surfaces. It is also ideal for around manholes, gutters, and drains. When applied properly Maxwell Mastic Gap creates a load bearing, weather resistant, durable bond resulting in a long-term pavement maintenance solution.

Mastic Gap Repairs:

1. 7th Ave. West – 7 cracks per the map: \$3,400.00
2. Adams Street West – 8 cracks per the map, 1 manhole & 1 water valve: \$4,100.00
3. Dayton Street East – 7 cracks and 100 ft. on edges of street and end of driveways: \$4,600.00
4. Creek View – 12 cracks and 100 ft. on edges of street and 1 manhole: \$7,200.00

If all the Gap is chosen to be completed, the price would be ~~\$19,300.00.~~

\$ 7,500.00

The above prices are subject to change if not accepted within 30 days.

The total project price is subject to the work chosen to be completed.

****The City of Arlington is responsible for notifying the public that we will be working in the area.**

**** Any bonds needed for this project would be extra.**

Acceptance of Proposal:

Date of acceptance: _____ PO # _____

Customer Signature: _____

M.R. Paving Signature: _____ / _____

Thank you for the opportunity to provide you with a quote for your community project.

Respectfully Submitted,

Brian D. Rahe

Brian D. Rahe, Sales Mgr.
M.R. Paving & Excavating, Inc.



**BOLTON
& MENK**

Real People. Real Solutions.

1960 Premier Drive
Mankato, MN 56001-5900

Ph: (507) 625-4171
Fax: (507) 625-4177
Bolton-Menk.com

MEMORANDUM

Date: August 15, 2023
To: Jessica Steinke, City Administrator
City of Arlington, Minnesota
From: Jake Pichelmann, P.E. – Bolton & Menk, Inc.
Copy: Lee Ortloff – PeopleService, Inc.
Subject: Quote Evaluation – WWTF Door Replacement
City of Arlington, Minnesota

Bolton & Menk, Inc. solicited quotations for replacing existing exterior hollow-metal doors at the Arlington Wastewater Treatment Facility (WWTF). The quotes received for the work are summarized in the table below.

BIDDERS	CONTACT	TOTAL PROJECT BASE BID PRICE	EXPECTED COMPLETION DATE
1. Vos Construction, Inc. 19063 371 st Ave. Green Isle, MN 55338	Scott Vos, President P: (507) 326-7901 scott@vosconstruction.com	\$54,470.00	November 15, 2023
2. MN Mechanical Solutions, Inc. 313 34 th Ave. S. Waite Park, MN 56387	Greg Braegelmann, President P: (320) 492-0198 greg@mnmechanical.com	\$59,500.00	Not provided
3. Gridor Constr. 3990 27 th Street SE Buffalo, MN 55313	Steve Lee, Project Manager P: (763) 746-9072 steve@gridor.com	\$62,000.00	December 1, 2023
4. Magney Construction, Inc. 1401 Park Road Chanhassen, MN 55317	Mark Magney, President P: (952) 474-1674 mark@magneyconstruction.com	\$64,990.00	May 31, 2024

Based on the quotes received, Vos Construction, Inc. out of Green Isle, Minnesota is the lowest, responsive, and responsible bidder with a Total Project Base Bid Price of \$54,470.00. Vos Construction is a local contractor that has experience in a wide variety of projects including the commercial, industrial, retail, religious, and municipal markets. They also have prior experience working in the City of Arlington.

We recommend the contract be awarded to Vos Construction, Inc. for the lump sum price bid of **\$54,470.00** and an expected completion date of November 15, 2023. The project includes replacing six (6) exterior hollow-metal doors, frames, glazing, and stainless steel hardware at the wastewater treatment facility. The work includes painting of the hollow-metal doors and frames. The existing doors were originally installed in 1989 (34 years old) and are due for replacement.

Copies of the contractor quote documents are attached to this memorandum.

ROOM FINISH SCHEDULE

ROOM NO.	FLOOR	BASE	WALLS	CEILING	NOTES
PRETREATMENT BLDG					
100 PRETREATMENT RM					
DIGESTER CONTROL BLDG					
101 LAB					
102 OFFICE					
103 MECHANICAL RM					
104 BATH					
105 HALL					
106 GENERATOR RM					
107 BLOWER RM					
108 BOILER RM					
109 GAS MIXING RM					

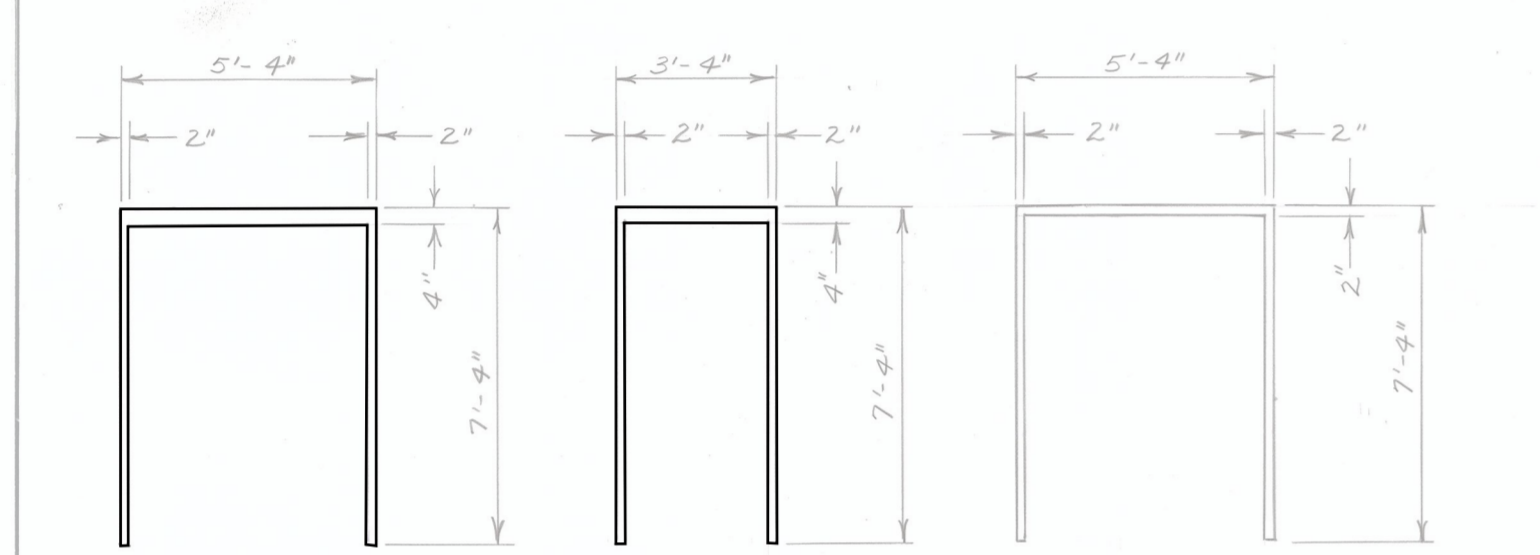

FRAME TYPES
SCALE: 1/4" = 1'-0"

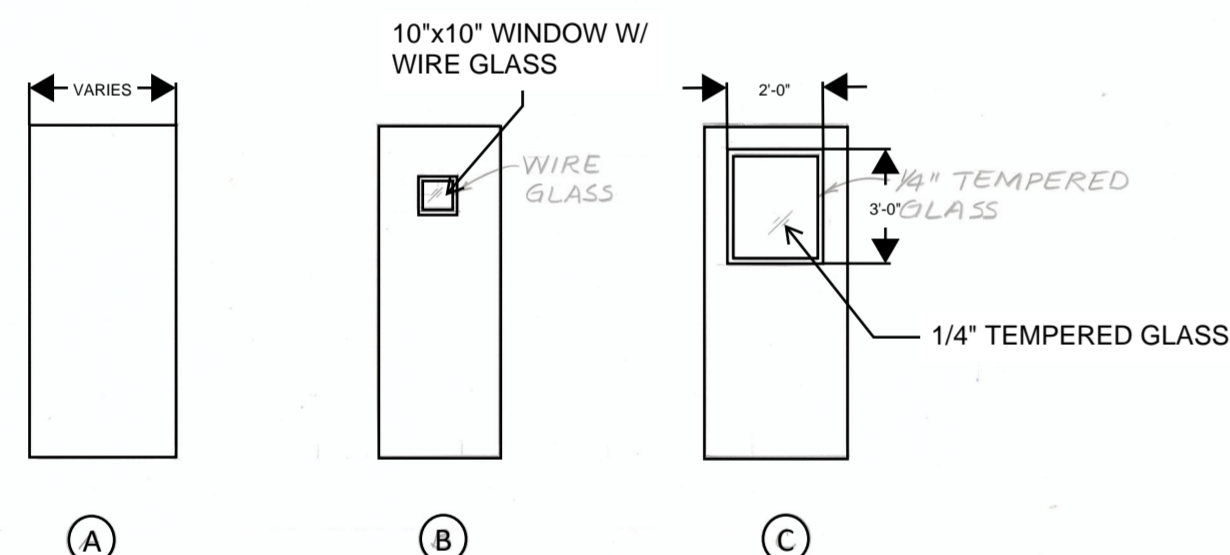

DOOR TYPES
SCALE: 1/4" = 1'-0"

DOOR SCHEDULE

DOOR #	DOOR						FRAME		FIRE RATING	HDWR GROUP	NOTES
	WIDTH	HEIGHT	THK	MATL	TYPE	GLAZ	MATL	TYPE			
105A	3'-0"	7'-0"	1 3/4"	HM	C	--	HM	2	--	#1 1	
105B	3'-0"	7'-0"	1 3/4"	HM	C	--	HM	2	--	#1 1	
106	(2) 2'-6"	7'-0"	1 3/4"	HM	A	--	HM	1	--	#2 1	
107A	3'-0"	7'-0"	1 3/4"	HM	A	--	HM	2	--	#1 1	
108	(2) 2'-6"	7'-0"	1 3/4"	HM	B	--	HM	1	--	#2 1	
109	(2) 2'-6"	7'-0"	1 3/4"	HM	A	--	HM	1	--	#2 1	

NOTES
1. CONTRACTOR TO FIELD VERIFY EXISTING DOOR DIMENSIONS AND REQUIREMENTS PRIOR TO ORDERING NEW DOORS, FRAMES, AND HARDWARE.

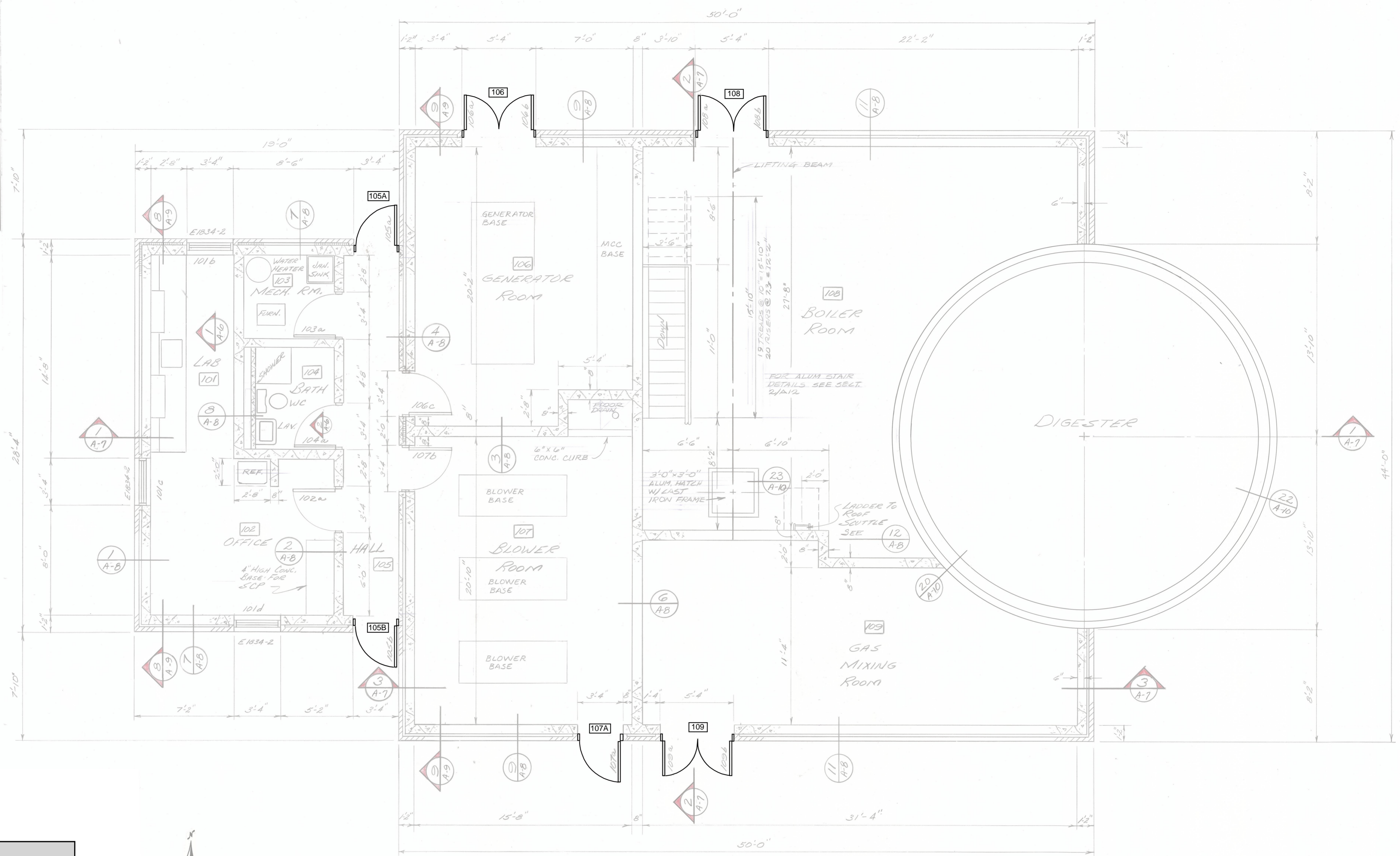

NOTE: STOOPS FOR DOORS WITH MASONRY FOUNDATIONS SHALL BE AS SHOWN IN DETAIL 10 - STOOP SECTION (TYP) AS SHOWN ON SHEET A-8.

STOOPS FOR DOORS WITH CAST-IN-PLACE FOUNDATIONS SHALL BE AS SHOWN IN DETAIL 5 - STOOP SECTION (TYP) AS SHOWN ON SHEET A-8.

This Record Drawing (or Corrected Specification) has been prepared based on information submitted, in part, by others. While this information is believed to be reliable, Bolton & Menk, Inc. is not responsible for its accuracy nor for errors or omissions which may have been incorporated into this document as a result.

I HEREBY CERTIFY THAT THIS PLAN, SPECIFICATION OR REPORT WAS PREPARED BY ME OR UNDER MY DIRECT SUPERVISION AND THAT I AM A DULY REGISTERED PROFESSIONAL ENGINEER UNDER THE LAWS OF THE STATE OF MINNESOTA.
Robert M. Menk
REG. NO. 13254

SUBMITTED
Project Engineer
RECOMMENDED
BOLTON & MENK, INC.
REG. NO. 13254
DATE 9-21-87

DESIGNED
DRAWN
CHECKED

BOLTON & MENK, INC.
CONSULTING ENGINEERS and LAND SURVEYORS
FAIRMONT MANKATO SLEEPY EYE

REV.	BY	DATE
1	lv	5-6-88
		9-21-90

ARLINGTON, MINNESOTA		SHEET
WASTEWATER TREATMENT IMPROVEMENTS		
DIGESTER CONTROL BUILDING FLOOR PLAN		A-5

PROPOSAL FOR

WASTEWATER TREATMENT FACILITY – DOOR REPLACEMENT



The undersigned, having become familiar with the local conditions affecting the cost of the work and with the drawings, schedules, and specifications attached to this proposal, hereby proposes to provide and furnish the necessary labor, materials, tools, and equipment to complete, in a workmanlike manner, all of the work required for replacing the existing exterior doors at the Wastewater Treatment Facility in accordance with the attached drawings, schedules, and specifications.

In submitting this quote, it is understood that the right is reserved by the Owner to reject any or all quotes and this quote may not be withdrawn for a period of thirty (30) days after the quote date. The Owner prefers this work to be done at the earliest possible date. Once the onsite installation work is started, the Contractor is expected to complete the work in its entirety and in a timely manner.

Please email quotes to Jake Pichelmann with Bolton & Menk, Inc. at jakeb.pichelmann@bolton-menk.com by **2:00 P.M. on Tuesday, August 15th, 2023**. Please contact Jake at (612) 750-6505 with any questions concerning the proposal documents. Coordinate site access with Lee Ortloff at LOrtloff@peopleservice.com or (612) 636-2434.

The undersigned proposed to perform the Work, furnish all material, and complete the Work in its entirety in the manner and under the conditions required for the Lump Sum Contract Price listed below. Quotes shall include sales tax and all applicable taxes and fees for materials furnished by the Contractor.

TOTAL PROJECT BASE BID PRICE (LUMP SUM)

1. Replacement of exterior doors at the Wastewater Treatment Facility as specified in this proposal and described in the specifications.

\$ 54,470.00

Fifty four thousand four hundred seventy dollars ^{no}/₁₀₀
DOLLARS)

Company Name: VOS CONSTRUCTION, LLC Signature: [Signature]
 Address: 19063 371ST AVE Name: SCOTT VOS
GREEN ISLE, MN 55338 Title: PRESIDENT
 Phone: 507-326-7901 Date: 8-15-23
 Email: scott@vosconstruction.com
 Expected Completion Date: 11-15-23

City Acceptance:
 Signature: _____ Date: _____
 Name: _____
 Title: _____

PROPOSAL FOR

WASTEWATER TREATMENT FACILITY – DOOR REPLACEMENT



The undersigned, having become familiar with the local conditions affecting the cost of the work and with the drawings, schedules, and specifications attached to this proposal, hereby proposes to provide and furnish the necessary labor, materials, tools, and equipment to complete, in a workmanlike manner, all of the work required for replacing the existing exterior doors at the Wastewater Treatment Facility in accordance with the attached drawings, schedules, and specifications.

In submitting this quote, it is understood that the right is reserved by the Owner to reject any or all quotes and this quote may not be withdrawn for a period of thirty (30) days after the quote date. The Owner prefers this work to be done at the earliest possible date. Once the onsite installation work is started, the Contractor is expected to complete the work in its entirety and in a timely manner.

Please email quotes to Jake Pichelmann with Bolton & Menk, Inc. at jakeb.pichelmann@bolton-menk.com by **2:00 P.M. on Tuesday, August 15th, 2023**. Please contact Jake at (612) 750-6505 with any questions concerning the proposal documents. Coordinate site access with Lee Ortloff at LOrtloff@peopleservice.com or (612) 636-2434.

The undersigned proposed to perform the Work, furnish all material, and complete the Work in its entirety in the manner and under the conditions required for the Lump Sum Contract Price listed below. Quotes shall include sales tax and all applicable taxes and fees for materials furnished by the Contractor.

TOTAL PROJECT BASE BID PRICE (LUMP SUM)

- 1. Replacement of exterior doors at the Wastewater Treatment Facility as specified in this proposal and described in the specifications.

\$ 59,500

fifty nine thousand five hundred and 00/100

DOLLARS)

Company Name: MW Mechanical Solutions Signature: [Signature]
 Address: 313 34th Ave S Name: Greg Broegelmann
White Park MN 56387 Title: President
 Phone: 320-492-0198 Date: 8-15-2023
 Email: greg@mwmechanical.com
 Expected Completion Date: _____

City Acceptance:

Signature: _____ Date: _____

Name: _____

Title _____

PROPOSAL FOR
WASTEWATER TREATMENT FACILITY – DOOR REPLACEMENT



The undersigned, having become familiar with the local conditions affecting the cost of the work and with the drawings, schedules, and specifications attached to this proposal, hereby proposes to provide and furnish the necessary labor, materials, tools, and equipment to complete, in a workmanlike manner, all of the work required for replacing the existing exterior doors at the Wastewater Treatment Facility in accordance with the attached drawings, schedules, and specifications.

In submitting this quote, it is understood that the right is reserved by the Owner to reject any or all quotes and this quote may not be withdrawn for a period of thirty (30) days after the quote date. The Owner prefers this work to be done at the earliest possible date. Once the onsite installation work is started, the Contractor is expected to complete the work in its entirety and in a timely manner.

Please email quotes to Jake Pichelmann with Bolton & Menk, Inc. at jakeb.pichelmann@bolton-menk.com by **2:00 P.M. on Tuesday, August 15th, 2023**. Please contact Jake at (612) 750-6505 with any questions concerning the proposal documents. Coordinate site access with Lee Ortloff at LOrtloff@peopleservice.com or (612) 636-2434.

The undersigned proposed to perform the Work, furnish all material, and complete the Work in its entirety in the manner and under the conditions required for the Lump Sum Contract Price listed below. Quotes shall include sales tax and all applicable taxes and fees for materials furnished by the Contractor.

TOTAL PROJECT BASE BID PRICE (LUMP SUM)

1. Replacement of exterior doors at the Wastewater Treatment Facility as specified in this proposal and described in the specifications. \$ 62,000.00
- (Sixty two thousand and no/100-----
 ----- DOLLARS)

Company Name: <u>Gridor Constr. Inc</u>	Signature:
Address: <u>3990 27th Street SE</u>	Name: <u>Steve Lee</u>
<u>Buffalo, MN 55313</u>	Title: <u>Project Manager</u>
Phone: <u>763-746-9072</u>	Date: <u>8/15/23</u>
Email: <u>steve@gridor.com</u>	<u>December 1, 2023 - if awarded</u>
Expected Completion Date:	<u>8/20/23.</u>

City Acceptance:
 Signature: _____ Date: _____
 Name: _____
 Title: _____

PROPOSAL FOR

WASTEWATER TREATMENT FACILITY – DOOR REPLACEMENT



The undersigned, having become familiar with the local conditions affecting the cost of the work and with the drawings, schedules, and specifications attached to this proposal, hereby proposes to provide and furnish the necessary labor, materials, tools, and equipment to complete, in a workmanlike manner, all of the work required for replacing the existing exterior doors at the Wastewater Treatment Facility in accordance with the attached drawings, schedules, and specifications.

In submitting this quote, it is understood that the right is reserved by the Owner to reject any or all quotes and this quote may not be withdrawn for a period of thirty (30) days after the quote date. The Owner prefers this work to be done at the earliest possible date. Once the onsite installation work is started, the Contractor is expected to complete the work in its entirety and in a timely manner.

Please email quotes to Jake Pichelmann with Bolton & Menk, Inc. at jakeb.pichelmann@bolton-menk.com by **2:00 P.M. on Tuesday, August 15th, 2023**. Please contact Jake at (612) 750-6505 with any questions concerning the proposal documents. Coordinate site access with Lee Ortloff at LOrtloff@peopleservice.com or (612) 636-2434.

The undersigned proposed to perform the Work, furnish all material, and complete the Work in its entirety in the manner and under the conditions required for the Lump Sum Contract Price listed below. Quotes shall include sales tax and all applicable taxes and fees for materials furnished by the Contractor.

TOTAL PROJECT BASE BID PRICE (LUMP SUM)

- 1. Replacement of exterior doors at the Wastewater Treatment Facility as specified in this proposal and described in the specifications. \$ 64,990.⁰⁰
- (SIXTY-FOUR THOUSAND, NINE HUNDRED
NINETY & ⁰⁰/100 _____ DOLLARS)

Company Name: Magney Construction, Inc. Signature: 

Address: 1401 Park Road Name: Mark Magney

Chanhassen, MN 55317 Title: President

Phone: 952-474-1674 Date: August 15, 2023

Email: mark@magneyconstruction.com

Expected Completion Date: May 31, 2024

City Acceptance:
Signature: _____ Date: _____

Name: _____

Title: _____



Arlington Police Department

Glenn Gerads, Chief of Police

108 4th Ave. NW, Arlington, MN 55307
Office: (507)964-5200 Fax: (507)964-2737
E-mail: police@arlingtonmn.gov

JULY 2023 – 462 Recorded ICR's

Traffic Stops	149
Business/Door Checks	113
Directed Patrol/Traffic Detail	26
Agency Assist	25
Park Checks	21
Informational	18
Public Relations/School Event	14
Animal Calls	12
Medical Calls	10
Suspicious Activity	9
Ordinance/Parking Violations	7
Residence Watch	7
Civil Matters	7
Driving Complaint	5
Public Assist	5
Noise Complaint	5
Welfare Checks	4
Vehicle Lockouts	3
911 Hang-up	3
Found Property	3
Theft	2
Alarms	2
Scams	2
Criminal Sexual Conduct	1
Property Damage	1
Juvenile Trouble/Truancy	1
Child Protection/Custody	1
Harassment Complaint	1
Warrant/Search Checks/Arrests	1
Death	1
Accidents	1
Fire Call	1
Open Door	1

Glenn Gerads #301
Chief of Police



Arlington Police Department

Glenn Gerads, Chief of Police

108 4th Ave. NW, Arlington, MN 55307
Office: (507)964-5200 Fax: (507)964-2737
E-mail: police@arlingtonmn.gov

JULY 2023

7-1-23

- Traffic Stop – Intersection Hwy 5 & 411th Ave.
- Business Check – 500 Block 2nd Ave. NW
- Traffic Stop – Intersection Hwy 5 & W. Baker St.
- Business Check – 500 Block 2nd Ave. NW
- Traffic Stop – Intersection 400 Block W. Chandler St.
- Informational – 100 Block 4th Ave. NW
- Directed Patrol – 400 Block E. Adams St.
- Animal Call – 500 Block W. Adams St.
- Civil Matter – 100 Block 4th Ave. NW
- Traffic Stop – Intersection 4th Ave. NE & Hwy 5
- 911 Hangup – 800 Block W. Chandler St.
- Business Check – 500 Block 2nd Ave. NW
- Business Check – 23200 Block 401st Ave.
- Directed Patrol – Intersection E. Brooks St. & 4th Ave. NE
- Business Check – 800 Block W. Chandler St.
- Traffic Stop – Intersection Hwy 5 & Sheila Dr.
- Traffic Stop – Intersection 411th Ave. & 228th Ln.
- Traffic Stop – Intersection 411th Ave. & W. Main St.
- Informational – 300 Block E. Main St.
- Park Check – 24200 Block 387th Ave.
- Traffic Stop – Intersection 401st Ave. & Henderson Rd.
- Traffic Stop – Intersection Hwy 5 & W. Chandler St.

7-2-23

- Traffic Stop – Intersection Hwy 5 & W. Baker St.
- Traffic Stop – Intersection Hwy 5 & Marion Dr.
- Agency Assist/Domestic – 800 Block Main Ave., Gaylord
- Business Check – 23100 Block 401st Ave.
- 911 Hangup – Intersection Cty. Rd. 166 & 395th Ln. (SO)
- Traffic Stop – Intersection Hwy 5 & W. Baker St.
- Directed Patrol – 600 Block Olive St.
- Business Check – 800 Block W. Chandler St.
- Business Check – 500 Block 2nd Ave. NW

7-3-23

- Medical Call/Agency Assist – 700 Block W. Main St.
- Informational – 100 Block 4th Ave NW
- Welfare Check – 800 Block W. Main St.
- Parking Violation – 300 Block E. Main St.
- Traffic Stop/Agency Assist – Intersection Hwy 5 & Cty. Rd. 13, Gaylord



Arlington Police Department

Glenn Gerads, Chief of Police

108 4th Ave. NW, Arlington, MN 55307
Office: (507)964-5200 Fax: (507)964-2737
E-mail: police@arlingtonmn.gov

- Business Check – 500 Block 2nd Ave. NW
- Informational – 100 Block 4th Ave. NW
- Business Check – 23200 Block 401st Ave.
- Business Check – 200 Block Shamrock Dr.
- Business Check – 600 Block W. Chandler St.
- Directed Patrol – 400 Block E. Adams St.
- Park Check – 300 Block 1st Ave. S.
- Park Check – 24200 Block 387th Ave.

7-4-23

- Business Check – 800 Block W. Chandler St.
- Noise Complaint/Agency Assist – 400 Block E. Adams St.
- Death/Agency Assist – 700 Block Chestnut Dr.
- Informational – 100 Block 4th Ave. NW
- Traffic Stop – Intersection Hwy 5 & W. Alden St.
- Directed Patrol – 400 Block E. Adams St.
- Directed Patrol – 600 Block Olive St.
- Agency Assist – Jefferson Ave. E., Gaylord
- Noise Complaint – 400 Block E. Adams St.
- Business Check – 23100 Block 401st Ave.
- Business Check – 300 Block W. Main St.
- Driving Complaint – Hwy 5
- Traffic Stop – Intersection Hwy 5 & 411th Ave. (SO)

7-5-23

- Business Check – 500 Block W. Main St.
- Business Check – 100 Block Henderson Rd.
- Traffic Stop – Intersection Hwy 5 & W. Main St.
- Scam – 600 Block W. Baker St.
- Ordinance Violation – 400 Block E. Dayton St.
- Suspicious Activity – 200 Block W. Main St.
- Traffic Stop – Intersection E. Main St. & 3rd Ave.
- Traffic Stop – Intersection Hwy 5 & 2nd Ave. NW
- Business Check – 500 Block 2nd Ave. NW
- Traffic Stop – Intersection Hwy 5 & 411th Ave.
- Traffic Stop – Intersection Main St. & 1st Ave.
- Business Check – 800 Block W. Chandler St.
- Traffic Stop – Intersection Hwy 5 & Marion Dr.
- Agency Assist – Intersection Division St. & Jefferson Ave., Gaylord
- Traffic Stop – Intersection Hwy 5 & 411th Ave.
- Park Check – 24200 Block 387th Ave.
- Business Check – 23100 Block 401st Ave.



Arlington Police Department

Glenn Gerads, Chief of Police

108 4th Ave. NW, Arlington, MN 55307
Office: (507)964-5200 Fax: (507)964-2737
E-mail: police@arlingtonmn.gov

7-6-23

- Found Property – 300 Block W. Chandler St.
- Animal Call – 500 Block W. Adams St.
- Traffic Stop – Intersection Cty. Rd. 17 & Henderson Rd.
- Traffic Stop – Intersection Cty. Rd. 9 & Hwy 5
- Business Check – 400 Block W. Main St.
- Agency Assist – 400 Block E. Adams St.
- Traffic Stop – Intersection Hwy 5 & 411th Ave.
- Traffic Stop – Intersection 3rd Ave. & Main St.
- Traffic Stop – Intersection Hwy 5 & W. Chandler St.
- Business Check – 23200 Block 401st Ave.
- Business Check – 500 Block W. Main St.
- Agency Assist/Animal Call – Intersection 371st Ave. & 228th St.
- Agency Assist/DUI – 46000 Hwy 19, Gaylord

7-7-23

- Residence Watch – 600 Block W. Brooks St.
- Public Assist – 700 Block Chestnut Dr.
- Business Check – 200 Block Shamrock Dr.
- Warrant Check – 200 Block E. Main St.
- Traffic Stop – Intersection Hwy 5 & 4th Ave.
- Directed Patrol – 400 Block E. Adams St.
- Business Check – 500 Block 2nd Ave. NW
- Business Check – 800 Block W. Chandler St.
- Directed Patrol – 600 Block Olive St.
- Juvenile Trouble/Medical Call/Agency Assist – 400 Block E. Adams St.
- Park Check – 400 Block 2nd Ave. NE
- Park Check – 600 Block W. Baker St.

7-8-23

- Park Check – 300 Block 1st Ave. S.
- Business Check – 600 Block W. Chandler St.
- Business Check – 300 Block W. Main St.
- Informational – 500 Block 2nd Ave. NW
- Medical Call/Agency Assist – 400 Block 7th Ave. NW
- Traffic Stop – Intersection 8th Ave. NW & W. Chandler St.
- Traffic Stop – Intersection 8th Ave. NW & W. Chandler St.
- Traffic Stop – Intersection 8th Ave. NW & W. Chandler St.
- Directed Patrol – 600 Block Olive St.
- Business Check – 800 Block W. Chandler St.



Arlington Police Department

Glenn Gerads, Chief of Police

108 4th Ave. NW, Arlington, MN 55307
Office: (507)964-5200 Fax: (507)964-2737
E-mail: police@arlingtonmn.gov

- Traffic Stop – Intersection Hwy 5 & Marion Dr.
- Traffic Stop – Intersection 411th Ave. & W. Chandler St.
- Business Check – 200 Block Shamrock Dr.
- Business Check – 500 Block 2nd Ave. NW
- Directed Patrol – 300 Block E. Main St.
- Business Check/Directed Patrol – 800 Block W. Chandler St.
- Vehicle Lockout – 800 Block W. Chandler St.
- Agency Assist/Driving Complaint – Intersection Cty. Rd. 9 & Cty. Rd. 15
- Park Check – 24200 Block 387th Ave.
- Residence Watch – 100 Block E. Baker St.
- Business Check – 200 Block Shamrock Dr.

7-9-23

- Business Check – 600 Block W. Chandler St.
- Business Check – 300 Block W. Main St.
- Traffic Stop – Intersection Hwy 5 & Cty. Rd. 17 (SO)
- Informational – 500 Block 2nd Ave. NW
- Traffic Stop – Intersection Hwy 5 & W. Chandler St.
- Traffic Stop – Intersection Marion Dr. & Shamrock Dr.
- Noise Complaint – 100 Block E. Dayton St.
- Public Relations – 500 Block Circle Ln.
- Business Check – 500 Block 2nd Ave. NW
- Directed Patrol/Public Relations – 400 Block E. Adams St.
- Noise Complaint – 200 Block E. Dayton St.
- Business Check – 800 Block W. Chandler St.
- Directed Patrol – 600 Block Olive St.
- Directed Patrol – 300 Block E. Main St.
- Alarm/Agency Assist – 400 Block W. Main St.
- Residence Watch – 600 Block E. Brooks St.
- Animal Call – 200 Block 6th Ave. SW
- Business Check – 500 Block 2nd Ave. NW
- Business Check – 100 Block 1st Ave. N.

7-10-23

- Medical Call/Agency Assist – 300 Block 5th Ave. NW
- Civil Matter – 100 Block 5th Ave. NW
- Informational – 500 Block W. Douglas St.
- Informational – 600 Block Marion Dr.
- Traffic Stop – Intersection Hwy 5 & 391st Ave.
- Informational – 100 Block 4th Ave. NW
- Theft – 300 Block W. Main St.



Arlington Police Department

Glenn Gerads, Chief of Police

108 4th Ave. NW, Arlington, MN 55307
Office: (507)964-5200 Fax: (507)964-2737
E-mail: police@arlingtonmn.gov

- Business Check – 100 Block 1st Ave. N.
- Traffic Stop – Intersection Hwy 5 & W. Main St.
- Suspicious Activity/Agency Assist – 400 Block W. Adams St.
- Directed Patrol – 400 Block E. Adams St.
- Business Check – 1100 Block Circle Dr.
- Suspicious Activity – 400 Block 4th Ave. NE
- Traffic Stop – Intersection Hwy 5 & Marion Dr.
- Traffic Stop – Intersection Hwy 5 & 411th Ave.

7-11-23

- Park Check/Public Relations – 300 Block 1st Ave. S.
- Residence Watch – 600 Block W. Brooks St.
- Driving Complaint – Intersection 3rd Ave. NW & W. Douglas St.
- Traffic Stop – Intersection W. Douglas St. & 3rd Ave. NW
- Directed Patrol – 400 Block E. Adams St.
- Business Check – 500 Block 2nd Ave. NW
- Traffic Stop – Intersection 411th Ave. & Hwy 5
- Traffic Stop – Intersection 1st Ave. & Main St.
- Traffic Stop – Intersection 1st Ave. & Main St.
- Business Check – 100 Block 5th Ave. NW
- Public Relations – Intersection Henderson Rd. & 4th Ave. SE
- Traffic Stop – Intersection Main St. & 1st Ave.
- Traffic Stop – Intersection 411th Ave. & Hwy 5
- Agency Assist/Warrant Arrest – 800 Block Main St., Gaylord
- Medical Call/Agency Assist – 600 Block Marion Dr.
- Business Check – 39500 Block 230th St.
- Agency Assist/Traffic Stop – 800 Block Main Ave., Gaylord
- Business Check – 600 Block W. Chandler St.
- Agency Assist/Traffic Stop – Intersection 7th St. & Main Ave., Gaylord
- Traffic Stop – Intersection Hwy 5 & 401st Ave.
- Traffic Stop – Intersection Hwy 5 & 411th Ave.

7-12-23

- Noise Complaint/Animal Call – 400 Block W. Elgin St.
- Business Check – 100 Block W. Shamrock Dr.
- Business Check – 200 Block Shamrock Dr.
- Business Check – 500 Block 2nd Ave. NW
- Traffic Stop – Intersection Hwy 5 & W. Chandler St.
- Traffic Stop – Intersection Hwy 5 & Cty. Rd. 9
- Business Check – 100 Block 1st Ave. N.
- Business Check – 800 Block W. Chandler St.



Arlington Police Department

Glenn Gerads, Chief of Police

108 4th Ave. NW, Arlington, MN 55307
Office: (507)964-5200 Fax: (507)964-2737
E-mail: police@arlingtonmn.gov

- Park Check – 24200 Block 387th Ave.
- Residence Watch – 600 Block W. Brooks St.
- Business Check – 500 Block W. Main St.
- Traffic Stop – Intersection Hwy 5 & W. Baker St.
- Traffic Stop – Intersection Hwy 5 & 4th Ave. NW

7-13-23

- Traffic Stop – Intersection Hwy 5 & W. Alden St.
- Medical Call/Agency Assist – 800 Block W. Main St.
- Civil Matter – 300 Block W. Chandler St.
- Animal Call – 300 Block E. Baker St.
- Directed Patrol – 400 Block E. Adams St.
- Agency Assist/Domestic – 33400 Block Rush River Park Rd., Henderson
- Traffic Stop – Intersection Hwy 5 & W. Baker St.
- Traffic Stop – Intersection 411th Ave. & W. Main St.
- Directed Patrol – 300 Block E. Main St.
- Traffic Stop – Intersection Hwy 5 & 411th Ave. (SO)
- Business Check – 800 Block W. Chandler St.
- Directed Patrol – 600 Block Olive St.
- Business Check – 23200 Block 401st Ave.
- Business Check – 100 Block 1st Ave. N.
- Residence Watch – 600 Block W. Brooks St.
- Business Check – 500 Block W. Main St.
- Traffic Stop – Intersection Hwy 5 & W. Alden St.

7-14-23

- Business Check – 600 Block W. Chandler St.
- Informational – 500 Block 2nd Ave. NW
- Informational – 100 Block 4th Ave. NW
- Traffic Stop – Intersection 4th Ave. NE & Hwy 5
- Medical Call/Agency Assist – 800 Block W. Main St.
- Traffic Stop – Intersection 411th Ave. & W. Main St.
- Traffic Stop – Intersection Cty. Rd. 17 & Henderson Rd.
- Business Check – 23200 Block 401st Ave.
- Traffic Stop – Intersection 411th Ave. & W. Main St.
- Traffic Stop – Intersection Hwy 5 & 411th Ave.
- Animal Call – 700 Block Marion Dr.
- Business Check – 500 Block 2nd Ave. NW
- Agency Assist/CSC – 400 Block 3rd St., Gaylord (*actual assist @ RSMC*)
- Traffic Stop – Intersection 4th Ave. SE & E. Dayton St.
- Park Check – 24200 Block 387th Ave.
- Business Check – 800 Block W. Chandler St.



Arlington Police Department

Glenn Gerads, Chief of Police

108 4th Ave. NW, Arlington, MN 55307
Office: (507)964-5200 Fax: (507)964-2737
E-mail: police@arlingtonmn.gov

7-15-23

- Agency Assist/Alarm – 100 Block 1st Ave. N. (SO)
- Traffic Stop – 500 Block Freedom Dr.
- Traffic Stop – Intersection Hwy 5 & W. Main St.
- Traffic Stop – Intersection 411th Ave. & Hwy 5
- Traffic Stop – Intersection 411th Ave. & Hwy 5
- Traffic Stop – Intersection Hwy 5 & 411th Ave.
- Traffic Stop – 100 Block W. Main St.
- Traffic Stop – Intersection 411th Ave. & Hwy 5
- Agency Assist/Traffic Stop – Intersection Hwy 22 & 290th St., Gaylord
- Business Check – 800 Block W. Chandler St.
- Business Check – 23100 Block Hwy 5
- Ordinance Violation – 600 Block W. Adams St.
- Suspicious Activity – 100 Block W. Main St.
- Traffic Stop – Intersection W. Chandler St. & 8th Ave. NW
- Traffic Stop – Intersection Hwy 5 & W. Adams St.
- Agency Assist/Warrant Attempt – 600 Block Court Ave., Gaylord
- Park Check – 300 Block 1st Ave. S.
- Agency Assist/Medical Call – 300 Block Lincoln Ave., Gaylord
- Traffic Stop – Intersection Hwy 5 & 411th Ave.

7-16-23

- Traffic Stop – Intersection Hwy 5 & 411th Ave.
- Traffic Stop – Intersection Hwy 5 & MM 6
- Business Check – 23100 Block 401st Ave.
- Traffic Stop – Intersection Hwy 5 & Marion Dr. (SO)
- Traffic Stop – Intersection Hwy 5 & 411th Ave.
- Traffic Stop – Intersection 411th Ave. & W. Chandler St.
- Traffic Stop/Agency Assist – Intersection Hwy 5 & W. Main St.
- Traffic Stop – Intersection Freedom Dr. & 4th Ave. SE
- Found Property – 24200 Block 387th Ave.
- Traffic Stop – Intersection Hwy 5 & Marion Dr.
- Business Check – 39500 Block 230th St.
- Business Check – 23200 Block 401st Ave.
- Public Relations – 300 Block 5th Ave. NW

7-17-23

- Found Property – 100 Block 4th Ave. NW
- Fire Call/Agency Assist – 200 Block Shamrock Dr.
- Vehicle Lockout – 200 Block Shamrock Dr.



Arlington Police Department

Glenn Gerads, Chief of Police

108 4th Ave. NW, Arlington, MN 55307
Office: (507)964-5200 Fax: (507)964-2737
E-mail: police@arlingtonmn.gov

- Medical Call/Agency Assist – 700 Block W. Main St.
- Business Check – 200 Block W. Main St.
- Ordinance Violation – 300 Block E. Brooks St.
- Business Check – 100 Block W. Main St.
- Traffic Stop – 200 Block W. Main St.
- Traffic Stop – Intersection E. Main St. & 2nd Ave.
- Traffic Stop – Intersection Hwy 5 & Marion Dr.
- Traffic Stop – Intersection Hwy 5 & W. Baker St.
- Public Relations/Public Event/Business Check – 200 Block Shamrock Dr.
- Business Check – 500 Block 2nd Ave. NW
- Traffic Stop – Intersection Hwy 5 & W. Main St.
- Business Check – 23200 Block 401st Ave.
- Business Check – 100 Block 1st Ave. N.
- Park Check – 300 Block 1st Ave. S.
- Traffic Stop – Intersection Cty. Rd. 12 & Hwy 5 (SO)
- Public Assist – 400 Block E. Adams St.

7-18-23

- Business Check – 600 Block W. Chandler St.
- Harassment Complaint – 100 Block W. Alden St.
- Animal Call/Ordinance Violation – 700 Marion Dr.
- Traffic Stop – Intersection 411th Ave. & W. Chandler St.
- Business Check – 200 Block Shamrock Dr.
- Ordinance Violation – 600 Block W. Brooks St.
- Suspicious Activity – 400 Block E. Main St.
- Public Relations – 500 Block Circle Ln.
- Traffic Stop – Intersection 4th Ave. NE & E. Alden St.
- Business Check – 500 Block 2nd Ave. NW
- Directed Patrol – 400 Block E. Adams St.
- Business Check – 23200 Block 401st Ave.
- Park Check – 24200 Block 387th Ave.
- Park Check – 300 Block 1st Ave. S.
- Traffic Stop – Intersection W. Main St. & W. Alden St. (SO)

7-19-23

- Business Check – 600 Block W. Chandler St.
- Informational/Med Disposal – 100 Block 4th Ave. NW
- Traffic Stop – Intersection Hwy 5 & 230th St.
- Traffic Stop – Intersection Hwy 5 & Marion Dr.
- Business Check – 400 Block W. Main St.
- Business Check – 23200 Block 401st Ave.



Arlington Police Department

Glenn Gerads, Chief of Police

108 4th Ave. NW, Arlington, MN 55307
Office: (507)964-5200 Fax: (507)964-2737
E-mail: police@arlingtonmn.gov

- Public Relations – 500 Block Circle Ln.
- Animal Call/Ordinance Violation – 700 Block Marion Dr.
- Animal Call/Ordinance Violation – 300 Block 1st Ave. N.

7-20-23

- Scam – 800 Block W. Main St.
- Welfare Check – 700 Block Chestnut Dr.
- Welfare Check – 700 Block Chestnut Dr.
- Informational – 300 Block W. Main St.
- Ordinance Violation – 300 Block E. Clinton St.
- Animal Call – 300 Block E. Main St.
- Traffic Stop – Intersection 411th Ave. & W. Main St.
- Business Check – 500 Block 2nd Ave. NW
- Traffic Stop – Intersection Cty. Rd. 17 & 250th St.
- Traffic Stop – Intersection 4th Ave. SE & E. Dayton St.
- Traffic Stop – Intersection Henderson Rd. & 1st Ave. S.
- Business Check – 100 Block 1st Ave. N.
- Open Door/Park Check/Agency Assist – 24200 387th Ave.
- 911 Hangup – 300 Block W. Alden St.
- Driving Complaint – Hwy 5 (SO)
- Traffic Stop – Intersection Hwy 5 & 411th Ave.

7-21-23

- Directed Patrol – 400 Block E. Adams St.
- Criminal Sexual Conduct – 500 Block W. Brooks St.
- Business Check – 200 Block Shamrock Dr.
- Civil Matter – 100 Block 5th Ave. NW
- Property Damage – 400 Block 7th Ave. NW
- Traffic Stop – Intersection 411th Ave. & W. Brooks St.
- Public Relations/Directed Patrol – 400 Block E. Adams St.
- Public Relations – 500 Block E. Elmwood St.
- Public Relations/Park Check – 300 Block 1st Ave. S.
- Traffic Stop – Intersection Hwy 5 & W. Brooks St.
- Traffic Stop – Intersection Marion Dr. & Shamrock Dr.
- Animal Call – 700 Block Chestnut Dr.
- Driving Complaint/Agency Assist – 500 Block E. Elmwood St.

7-22-23

- Suspicious Activity – 200 Block Shamrock Dr.
- Traffic Detail – McGrann Street, Green Isle
- Business Check – 200 Block Shamrock Dr.



Arlington Police Department

Glenn Gerads, Chief of Police

108 4th Ave. NW, Arlington, MN 55307
Office: (507)964-5200 Fax: (507)964-2737
E-mail: police@arlingtonmn.gov

- Directed Patrol – 300 Block 8th Ave. NW
- Business Check – 500 Block 2nd Ave. NW
- Business Check – 200 Block Shamrock Dr.
- Agency Assist/Driving Complaint – Hwy 5, Green Isle
- Directed Patrol – 400 Block E. Adams St.
- Agency Assist/Fire Call – Intersection Jessenland Rd. & 345th Ave., Green Isle
- Business Check – 23200 Block 401st Ave.
- Business Check – 800 Block W. Chandler St.
- Traffic Stop – Intersection 411th Ave. & W. Chandler St.
- Directed Patrol – 400 Block E. Adams St.

7-23-23

- Traffic Stop – Intersection Hwy 5 & W. Adams St.
- Traffic Stop – Intersection Hwy 5 & 411th Ave.
- Agency Assist/Public Assist – Intersection Hwy 5 & 381st Ave., Green Isle
- Civil Matter – 500 Block W. Brooks St.
- Public Assist – 500 Block W. Baker St.
- Business Check – 800 Block W. Chandler St.
- Traffic Stop – Intersection Hwy 5 & W. Baker St.
- Directed Patrol – 400 Block E. Adams St.
- Public Relations – 500 Block Circle Ln.
- Business Check – 200 Block Shamrock Dr.
- Public Relations – 700 Block Marion Dr.
- Business Check – 300 Block W. Main St.
- Business Check – 100 Block 1st Ave. N.
- Park Check – 300 Block 1st Ave. S.
- Suspicious Activity – 400 Block 2nd Ave. NE
- Business Check – 23100 Block 401st Ave.
- Traffic Stop – Intersection Hwy 5 & Marion Dr.

7-24-23

- Traffic Stop – Intersection Cty. Rd. 12 & Circle Dr. (SO)
- Welfare Check – 100 Block W. Alden St.
- Public Relations – 400 Block 4th Ave. NW
- Traffic Stop – Intersection Hwy 5 & 230th St.
- Civil Matter – 400 Block E. Adams St.
- Business Check – 23200 Block 401st Ave.
- Public Relations – 700 Block Marion Dr.
- Traffic Stop – Intersection Hwy 5 & Marion Dr.
- Traffic Stop – Intersection Hwy 5 & W. Brooks St.
- Traffic Stop – Intersection Hwy 5 & 401st Ave. (SO)



Arlington Police Department

Glenn Gerads, Chief of Police

108 4th Ave. NW, Arlington, MN 55307
Office: (507)964-5200 Fax: (507)964-2737
E-mail: police@arlingtonmn.gov

- Business Check – 100 Block 1st Ave. N.
- Park Check – 300 Block 1st Ave. S.
- Park Check – 24200 Block 387th Ave.
- Suspicious Activity – 24200 Block 387th Ave.

7-25-23

- Traffic Stop – Intersection Hwy 5 & 411th Ave.
- Theft – 23200 Block 401st Ave.
- Traffic Stop – Intersection E. Clinton St. & 4th Ave. SE
- Traffic Stop – Intersection Hwy 5 & W. Brooks St.
- Traffic Stop – Intersection Hwy 5 & W. Chandler St.
- Traffic Stop – Intersection 411th Ave. & Hwy 5
- Traffic Stop – Intersection Cty. Rd. 17 & Henderson Rd.
- Traffic Stop – Intersection 2nd Ave. & Alden St.
- Traffic Stop – Intersection Hwy 5 & 411th Ave.
- Business Check – 23100 Block 401st Ave.
- Traffic Stop – Intersection Hwy 5 & 4th Ave. NW
- Business Check – 500 Block W. Main St.
- Business Check – 800 Block W. Chandler St.
- Traffic Stop – Intersection 5th Ave. & W. Main St.

7-26-23

- Business Check – 200 Block Shamrock Dr.
- Public Relations – 600 Block 4th Ave. SE
- Traffic Stop – Intersection Hwy 5 & W. Baker St.
- Informational – 200 Block Shamrock Dr.
- Traffic Stop – Intersection Hwy 5 & W. Alden St.
- Informational – 100 Block 4th Ave. NW
- Traffic Stop – Intersection Hwy 5 & W. Main St.
- Traffic Stop – Intersection Hwy 5 & 4th Ave. NW
- Driving Complaint – Hwy 5
- Alarm – 100 Block 7th Ave. SW
- Business Check – 100 Block 1st Ave. N.
- Traffic Stop – Intersection 2nd Ave. NW & Hwy 5
- Traffic Stop – Intersection Hwy 5 & 226th St.
- Park Check – 24200 Block 387th Ave.
- Traffic Stop – Intersection Hwy 5 & 2nd Ave. NW
- Traffic Stop – Intersection Hwy 5 & W. Adams St.
- Traffic Stop – Intersection Hwy 5 & W. Baker St.



Arlington Police Department

Glenn Gerads, Chief of Police

108 4th Ave. NW, Arlington, MN 55307
Office: (507)964-5200 Fax: (507)964-2737
E-mail: police@arlingtonmn.gov

7-27-23

- Business Check – 600 Block W. Chandler St.
- Medical Call/Agency Assist – 400 Block Cottonwood St., Winthrop (*actual assist @ RSMC*)
- Vehicle Lockout – 100 Block Henderson Rd.
- Business Check – 500 Block 2nd Ave. NW
- Traffic Stop – Intersection W. Alden St. & 4th Ave. NW
- Business Check/Public Relations – 400 Block W. Main St.
- Directed Patrol – 400 Block E. Adams St.
- Public Assist – Intersection Henderson Rd. & 4th Ave. SE
- Civil Matter – 200 Block W. Elgin St.
- Business Check – 500 Block 2nd Ave. NW
- Traffic Stop – Intersection Hwy 5 & 401st Ave.
- Business Check – 23200 Block 401st Ave.
- Business Check – 100 Block 1st Ave. N.
- Medical Call/Agency Assist – 700 Block Chestnut Dr.
- Agency Assist – 400 Block E. Adams St.

7-28-23

- Business Check – 600 Block W. Chandler St.
- Traffic Stop – Intersection 1st Ave. & Main St.
- Ordinance Violation – 700 Block W. Brooks St.
- Traffic Stop – Intersection Hwy 5 & W. Chandler St.
- Business Check – 500 Block 2nd Ave. NW
- Traffic Stop – Intersection 411th Ave. & W. Main St.
- Traffic Stop/Agency Assist – Intersection Hwy 5 & W. Chandler St.
- Agency Assist/Runaway – Lincoln Ave., Gaylord
- Agency Assist/911 Hangup – 800 Block Main Ave., Gaylord
- Agency Assist/Domestic – Intersection Commercial Ave. S. & 4th St., Gaylord
- Park Check – 300 Block 1st Ave. S.

7-29-23

- Business Check – 200 Block 3rd Ave. NW
- Business Check – 1100 Block Circle Ln.
- Business Check – 200 Block W. Main St.
- Residence Watch – 400 Block E. Main St.
- Business Check – 500 Block 2nd Ave. NW
- Traffic Stop – Intersection Hwy 5 & W. Adams St.
- Traffic Stop – Intersection Hwy 5 & W. Brooks St.
- Traffic Stop – Intersection 411th Ave. & W. Chandler St.
- Traffic Stop – Intersection Hwy 5 & 4th Ave. NW



Arlington Police Department

Glenn Gerads, Chief of Police

108 4th Ave. NW, Arlington, MN 55307
Office: (507)964-5200 Fax: (507)964-2737
E-mail: police@arlingtonmn.gov

- Traffic Stop – Intersection 4th Ave. SE & E. Dayton St.
- Business Check – 23200 Block 401st Ave.
- Traffic Stop – Intersection 4th Ave. NE & E. Brooks St.
- Business Check – 200 Block Shamrock Dr.
- Business Check – 39500 Block 230th St.
- Agency Assist/Pursuit – Intersection Hwy 25 & Hwy 5, Green Isle
- Agency Assist/Suspicious Activity – Intersection Kilkenny Ave. & Western Ave., Gaylord
- Business Check – 200 Block Shamrock Dr.
- Suspicious Activity – 300 Block E. Adams St.
- Park Check – 24200 Block 387th Ave.

7-30-23

- Traffic Stop – Intersection Hwy 5 & Marion Dr.
- Traffic Stop – Intersection Hwy 5 & 411th Ave.
- Informational – 100 Block W. Alden St.
- Traffic Stop – Intersection 411th Ave. & W. Main St.
- Traffic Stop – Intersection 411th Ave. & Hwy 5
- Traffic Stop – Intersection Main St. & 1st Ave.
- Traffic Stop – Intersection Hwy 5 & W. Main St.
- Traffic Stop – Intersection Hwy 5 & W. Alden St.
- Traffic Stop – 300 Block W. Main St.
- Animal Call – 100 Block 4th Ave. NW
- Business Check – 100 Block 1st Ave. NW
- Medical Call/Agency Assist – 400 Block 2nd Ave. NE

7-31-23

- Child Protection – 100 Block 4th Ave. NW
- Accident/Agency Assist – Intersection Hwy 5 & 4th Ave.
- Public Assist – 100 Block 4th Ave. NW
- Informational – 100 Block 4th Ave. NW
- Animal Call – 100 Block 7th Ave. SW

Glenn Gerads #301
Chief of Police