



**ECONOMIC DEVELOPMENT AUTHORITY
MEETING AGENDA
MARCH 8 @5:30 P.M.
Arlington Community Center - Council Chambers**

Join from PC, Mac, Linux, iOS or Android:

<https://meetings.ringcentral.com/j/1491721782?pwd=cGtvdHQ1Umh5NHFUVDfiQjF3eGdMdz09>

Password: 005845

For the best audio experience, please use computer audio.

Or Telephone:

Dial(for higher quality, dial a number based on your current location):

US: +1(646)3573664

+1(773)2319226

+1(312)2630281

+1(470)8692200

+1(213)2505700

+1(346)9804201

+1(469)4450100

+1(623)4049000

+1(650)2424929

+1(720)9027700

Meeting ID: 149 172 1782

International numbers available: <https://meetings.ringcentral.com/teleconference>

1. Call to Order
2. Pledge of Allegiance
3. Approval of Agenda
4. Approval of Minutes
 - A. February 8, 2021
5. Approval of Financial Reports
 - A. February 2021
6. New Business
 - A. Consider proposal from Tony Hoff to purchase the Nickel Property
 - B. Discussion on Hennen land
 - C. RESOLUTION 1-2021 A RESOLUTION APPROVING A SIGN LOAN TO BRANDON BRINKMAN d.b.a. GRAND K LLC, LOCATED AT 229 WEST MAIN STREET
 - D. Tractor Pull Event in Arlington – Craig Buss

7. Old Business

8. Public Hearing regarding the proposed Dog Park – 6 pm.

9. Planning and Zoning update

- I. Comprehensive Plan (binders)
- II. Orderly Annexation (binders)
- III. Scott Equipment expansion

10. EDA Director update on businesses and housing

11. Director and Board Comments

12. Adjourn



**ECONOMIC DEVELOPMENT AUTHORITY
MEETING MINUTES
FEBRUARY 8 @5:30 P.M.
Arlington Community Center - Council Chambers**

Join from PC, Mac, Linux, iOS or Android:

<https://meetings.ringcentral.com/j/1482389954?pwd=N3hPUk5tRWRIQi94dVJhQW9oSIFtZz09>

Password: 014990

For the best audio experience, please use computer audio.

Or Telephone:

Dial (for higher quality, dial a number based on your current location):

US: +1(646)3573664

+1(773)2319226 (US North)

+1(312)2630281

+1(470)8692200 (US East)

+1(650)2424929

+1(720)9027700 (US Central)

+1(213)2505700

+1(346)9804201

+1(469)4450100 (US South)

+1(623)4049000 (US West)

Meeting ID: 148 238 9954

International numbers available: <https://meetings.ringcentral.com/teleconference>

1. Call to Order: Meeting was called to order at 5:30 PM by President Kurt Menk.
Present: Larry Sorenson, Matthew Scharpe, Dean Bergersen, Howard Brinkman, Craig Buss, Kurt Menk
Absent: Tim Kloeckl
Staff Present: EDA Director Amy Newsom, Community Development Intern Haile Tegegne
Guests Present: none.
2. Pledge of Allegiance – All stood for the Pledge of Allegiance.
3. Approval of Agenda – Motion by Bergersen to approve the agenda, second by Scharpe.

4. Approval of Minutes
 - A. January 11, 2021 – Motion by Sorenson to approve the minutes, second by Buss.

5. Approval of Financial Reports – Motion by Scharpe to approve the Financial Reports, second by Bergersen. Motion Carried. All in favor.
 - A. December 2020
 - B. January 2021

6. New Business
 - A. 2020 Annual Report – Newsom presented the 2020 Annual Report. Consensus to approve the report. President Kurt Menk will present to Council.
 - B. Recommendation from citizen for Industrial Park land – 70 acres for sale outside of city limits. EDA Board decided against considering the parcel due to the distance from the City and cost to run infrastructure.

7. Old Business
 - A. Marketing Update – Tegegne gave an update on marketing. Decided against marketing in the Star-Tribune due to the quality and cost of the ad. Tegegne presented other options for advertising.
 - B. Acres to grow crops – Tegegne also spoke about interest from the metro to purchase a few acres of cropland in the area to grow fruits and vegetables for Farmer’s Markets, etc.**

8. Planning and Zoning update
 - I. Dog Park Update – Consensus of the EDA to hold a public Hearing at the next EDA meeting.
 - II. Comprehensive Plan – Newsom will present copies of the Comprehensive Plan for the EDA to update throughout the year.
 - III. Orderly Annexation -Newsom will also present copies of information on the orderly annexation. EDA and P&Z will work together on both the comprehensive plan and orderly annexation.

9. EDA Director update on businesses and housing
 - I. FillMe Up Pitstop – Newsom attended the ribbon cutting event with Nagel and Tegegne.
 - II. A-Town Tavern – Grand opening coming up this week.
 - III. Bakery and Liquor Store – Discussed the limits of liquor license is regulated by Minnesota state.
 - IV. Commercial lots for sale – Still advertising the Nickel and Swenson properties. EDA Board would like Newsom to reach out to Tony Hoff again regarding the Nickel property.
 - V. Housing – Tegegne has connected the Patel group with Mike Westphalen, the real estate agent, to discuss building twin homes in the Frenzel addition.

10. Director and Board Comments
 - I. Arlington Days on KNUJ February 12 – Newsom will represent Choose Arlington.

11. Open Discussion - Buss would like to bring a tractor pull event to town that will bring people from all over the state. He will do more research and present at next meeting.

12. Adjourn Motion by Sorenson to adjourn the meeting ended 7:11 PM Second by Bergersen. Motion Carried.

EDA Director Amy Newsom

EDA President Kurt Menk

March 9, 2020

Tony's Outdoor Services
PO Box 275
Henderson, MN 56044
612-328-3860
tony@tonysoutdoorservices.com

Arlington EDA
204 Shamrock Dr,
Arlington, MN 55307

Dear Arlington EDA,

It is with deep respect that I submit this proposal to the Arlington MN EDA. I would like to purchase the entire Nickel property. My intention is to have 5 fulltime employees working for my company. I will pay the city of Arlington 10,000 dollars for the property.

Tony's outdoor service is an excavation and contracting company. We do a lot of work for Sibley county ditches. Our services include washout repair, tree removal and invasive species control to name a few. We do a lot of conservation work for the D.N.R. including wetland restoration, tree and brush removal and invasive species control. I have a vast background in a lot of different projects. My company does anything from digging basements, sewer and water and all the way up to large scale commercial buildings.

My intent is to put up a 60x80 pole shed that would have 18-foot side walls. The entrance for the shop would be facing the east and the front of the building would face County Rd 9.

Sibley County contractors will be given the opportunity to bid on the building.

I am very excited about the opportunity to move my business to Arlington and look forward to your consideration.

Sincerely,

Tony Hoff
President of Tony's Outdoor Services

Amy Newsom

From: Laura Hacker <lauraw@co.sibley.mn.us>
Sent: Monday, April 13, 2020 2:07 PM
To: Amy Newsom; Mike Kedrowski
Subject: Estimated EMV and Tax Amount - Hoff Project (Old Nickel)

Michael & Amy:

Below is a rough estimate of the Estimated Market Value and Tax Amount for the proposed Hoff project (old Nickel property 31.0874.000).

This estimate is based upon the information provided and is subject to change if or when the project is built.

The tax amount is based upon the rates for payable 2020.

If you have any questions, let me know.

Estimated EMV \$290,200
Estimated Total Tax \$9,628

Laura Hacker, SAMA

County Assessor - Director

Sibley County Assessor's Office

Property Assessing & Zoning Department

(507) 237-4075

lauraw@co.sibley.mn.us



Sibley County: Providing quality public service in a cost effective manner through innovation, leadership and cooperation.

"This e-mail (including any attachments) may contain information which is confidential. This e-mail (including any attachments) is intended only for the use of the person or entity to whom it is addressed. If you have received this e-mail in error, do not distribute, copy or disseminate. Return the e-mail to the sender, delete the e-mail, and notify the sender by telephone at (507) 237-4075."

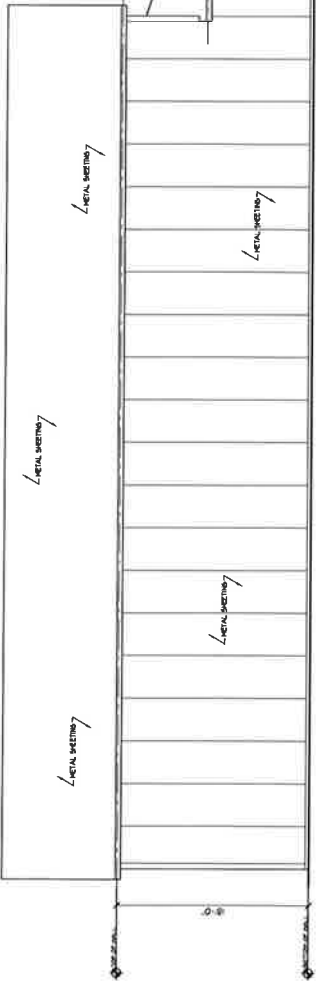

1 SIDE WALL ELEVATION
SCALE: 1/8" = 1'-0"

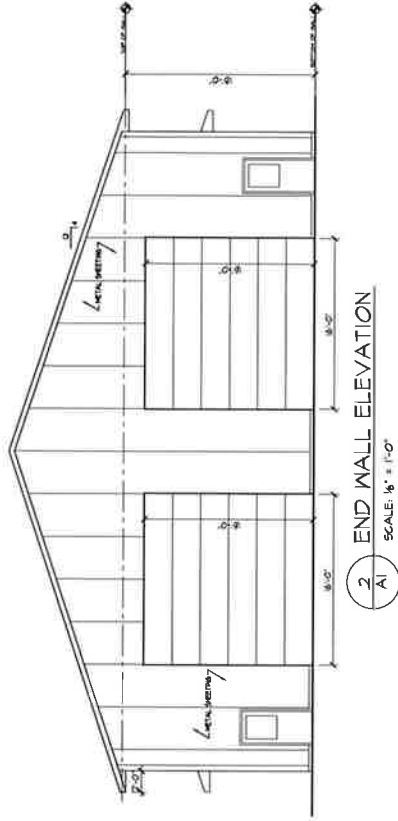

2 END WALL ELEVATION
SCALE: 1/8" = 1'-0"

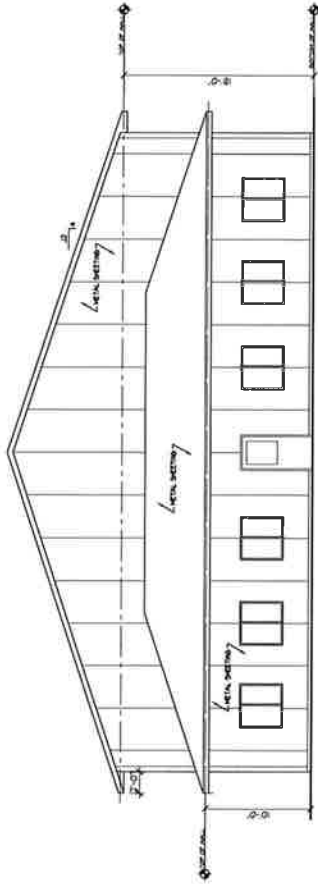

3 END WALL ELEVATION
SCALE: 1/8" = 1'-0"

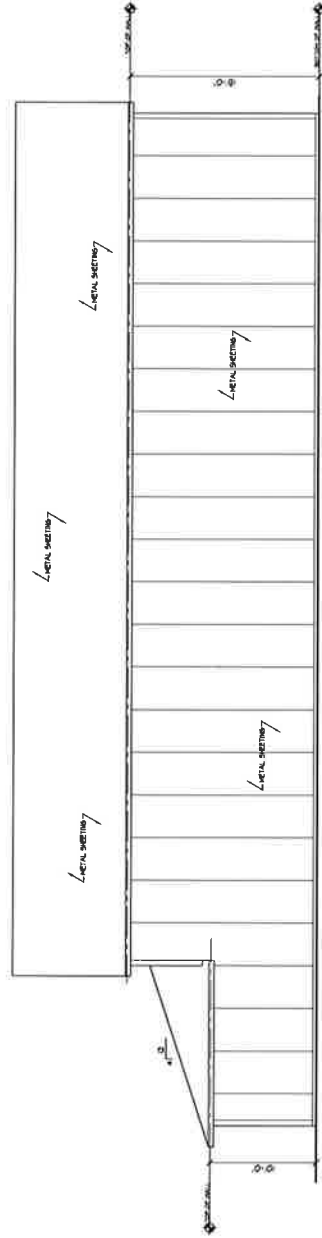

4 SIDE WALL ELEVATION
SCALE: 1/8" = 1'-0"

SHEET INDEX

- A1 - EXT ELEVATIONS
- A2 - FLOOR PLAN & SECTION

- NOTES**
1. ALL HEADERS AND LINTELS THIS PLAN;
 - (2) - 2x4 UNLESS NOTED OTHERWISE

GENERAL DATA

- A. CONSTRUCTION GROUP - S-1
- B. CONSTRUCTION TYPE - V-F
- C. CONSTRUCTION TYPE - V-N
- D. SNOW LOAD - 35 PSF
- E. WIND LOAD - 20 PSF
- F. SOIL BEARING - ASSUMED 1500 PSF

STRUCTURAL DATA

- A. CONCRETE PIERS - 3000 PSI
- B. CONCRETE FLOOR - 4000 PSI, EA. AIR ENTR.
- C. POSTS - TRTD. L2000 MIN. dfl. NO. 1
- D. GIRTS & RAFTERS - 12 BEM-FIR
- E. ENGINEERED TRUSSES - 10 PSF DL + 25 PSF SL

THIS BUILDING MEETS OR EXCEEDS ALL CURRENT MINNESOTA BUILDING CODES

BEHR
CREATING TIMELESS DESIGN

OFFICE (952) 746-7702 | FAX (952) 746-7703
CELL (952) 994-6882
E-MAIL: mlk@behr-design.com

BEHR DESIGN, INC. YOU AS A CLIENT HAVE AN INVESTMENT IN YOUR BUILDING. YOUR BUILDING IS AN INVESTMENT IN YOUR BUSINESS. YOUR BUILDING IS AN INVESTMENT IN YOUR FUTURE. YOUR BUILDING IS AN INVESTMENT IN YOUR LIFE. YOUR BUILDING IS AN INVESTMENT IN YOUR WELL-BEING. YOUR BUILDING IS AN INVESTMENT IN YOUR HAPPINESS. YOUR BUILDING IS AN INVESTMENT IN YOUR SUCCESS. YOUR BUILDING IS AN INVESTMENT IN YOUR DREAMS. YOUR BUILDING IS AN INVESTMENT IN YOUR LEGACY. YOUR BUILDING IS AN INVESTMENT IN YOUR FUTURE. YOUR BUILDING IS AN INVESTMENT IN YOUR LIFE. YOUR BUILDING IS AN INVESTMENT IN YOUR WELL-BEING. YOUR BUILDING IS AN INVESTMENT IN YOUR HAPPINESS. YOUR BUILDING IS AN INVESTMENT IN YOUR SUCCESS. YOUR BUILDING IS AN INVESTMENT IN YOUR DREAMS. YOUR BUILDING IS AN INVESTMENT IN YOUR LEGACY.

SIEWEK LUMBER & MILLWORK

Tony Hoff
Arlington, MN



SHEET NO. A1

EXTENSION



XX HIGHWAY 5
ARLINGTON, MN 55307

\$178,320

\$807/MO



14.86
 ACRES

—
 ZONING

13 DAYS
 ON WEBSITE

ACTIVE
 STATUS

Unique opportunity - 14.86 acres in the city limits of Arlington. City zoning allows for One and Two Family Dwellings and Service Business District - Contact City with zoning questions.

I'm Interested

FIRST NAME



EMAIL ADDRESS

Enter your email address

PHONE (OPTIONAL)

Enter your phone number

Schedule a showing

In Person

Virtual

NEW

CONTINUE

My Places

Register or sign in to see estimated driving times between properties and places important to you.



- Grocery stores** ▶
- Restaurants** ▶
- Coffee Shops** ▶
- Shopping** ▶
- Nightlife** ▶



Calculate commute time

Leave feedback

© 2020 Google p data Leaflet



Details

INTERIOR

BUILDING AND CONSTRUCTION

Property Sub Type

Land

Property Type

Land

EXTERIOR AND LOT

Lot Size Acres

14.86

Lot Size Square Feet

647302

Lot Size Units

Acres

AREA AND SCHOOLS



Arlington



County Or Parish

Sibley

High School District

Sibley East

Subdivision Name

Frenzel Add

FINANCIAL INFO

Tax Annual Amount

\$1,011.00

Tax Year

2020

Listing By RE/MAX Experience

MLS# 5714823

Data Last Updated 11:17am - 03/04/2021



By searching, you agree to the Terms of Use, and Privacy Policy: Some or all of the property listings above may have been submitted to the Northstar MLS by the listing



Results is licensed in the state of Minnesota. The data relating to real estate for sale on this web site comes in part from the Broker ReciprocitySM Program of the Northstar MLS, Inc. IDX information is provided exclusively for consumers' personal, non-commercial use and may not be used for any purpose other than to identify prospective properties consumers may be interested in purchasing. RE/MAX Results is not a Multiple Listing Service (MLS), nor does it offer MLS access. This website is a service of RE/MAX Results, a broker Participant of the Northstar MLS, Inc. Open House information is subject to change without notice. The listings of some real estate brokerage firms have been excluded. Information deemed reliable but not guaranteed. Copyright© 2021 Northstar MLS. All Rights Reserved.

Comparable Listings



XXX 631ST AVENUE, I

\$175,000



Schools

NAME	GRADES	STUDENT/ TEACHERS	STATEWIDE RANKING
SIBLEY EAST ELEMENTARY SCHOOL - ARLINGTON CAMPUS	PK/ 06	15.2 / 1	
SIBLEY EAST HIGH SCHOOL	01 / 01	14.8 / 1	246
SIBLEY EAST ELEMENTARY SCHOOL GAYLORD CAMPUS	PK/ 06	13.6 / 1	649
SIBLEY EAST JUNIOR HIGH SCHOOL	07 / 09	16.8 / 1	341

Mortgage Calculator

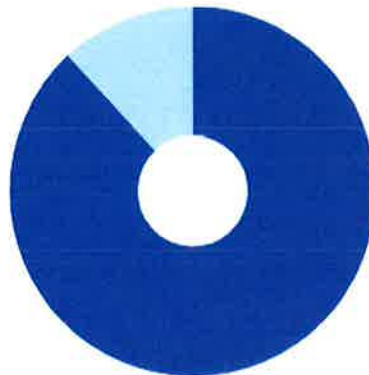

Estimated Payment: \$708/month

PURCHASE PRICE

\$178,320



3.2370



DOWN PAYMENT

20%

\$35,664

LOAN TYPE

30-Year Fixed

TAXES (YEARLY)

\$1,011

INSURANCE (YEARLY)

\$0

PMI (MONTHLY)

\$0

OTHER (MONTHLY)

\$0

Estimated monthly payment amount is based on a default "Purchase Price" as the list price for the applicable home. Default "Interest Rate" is the national average 30-Year Fixed Rate Mortgage Average in the United States loan rate as of Thursday, March 5th 2020 according to Quandl. Default "Taxes (Yearly)" is based on NMLS and tax record data based on the property address. "Down Payment" default is 20% which results in a default "PMI (Monthly)" of \$0. For "Down Payment" of less than 20%, "PMI (monthly)" amount is calculated based on the "Purchase Price", "Loan Type" and "Down Payment Amount" and is approximately 2% of \$142,656. "Insurance (Yearly)" reflects estimated data entered by you. "Other (Monthly)" reflects estimated data entered by you. Your actual payment may be higher or lower and all loans are subject to credit approval.

Listed By



Mark Kottke

Broker Owner

License# 40571174

 (612) 382-4510

[CONTACT ME](#)



EDA RESOLUTION NO. 1-2021

**A RESOLUTION APPROVING A SIGN LOAN TO BRANDON BRINKMAN d.b.a. GRAND K LLC,
LOCATED AT 229 WEST MAIN STREET**

Motion by Commissioner _____ Seconded by Commissioner _____

WHEREAS, Brandon Brinkman d.b.a. Grand K LLC, applied for Sign Loan available through the EDA; and

WHEREAS, the Applicant requests a forgivable loan in the amount of \$1,000.00 or fifty (50) percent of the actual project cost, whichever is less; and

WHEREAS, the purpose of the loan is to add a sign to his business, located at 229 West Main Street; and

WHEREAS, the EDA has reviewed the application and determined compliance with loan policies and procedures,

NOW, THEREFORE, BE IT RESOLVED, that the Arlington Economic Development Authority hereby approves a sign program loan in the amount of \$1,000.00 to Brandon Brinkman as follows:

1. The City and EDA approved the Sign Program which is administered by the Arlington EDA.
2. Brandon Brinkman d.b.a. Grand K LLC has submitted an official application form requesting financial assistance from the EDA Sign Program in the amount of \$1,000.00 or fifty (50) percent of the project cost, whichever is less to: add a sign to his business property located at 229 West Main Street
3. The Loan is to be made from the EDA Fund #204 (Facade Improvement Loan Program) fund and will be forgiven three years following the disbursement of the loan if the project is completed within a reasonable period defined as 180 days.
4. The EDA hereby approves the loan proposed contingent on:
 - a. Sign permit approved.
 - b. Follow the City's Zoning Ordinance.

Yes No Abstain Absent

Bergersen
Brinkman
Buss
Kloeckl
Menk
Scharpe
Sorenson

Adopted by the Economic Development Authority of the City of Arlington this 8th day of
March, 2021

Signed: _____
Kurt Menk President

Attest: _____
Amy Newsom, EDA Director



Arlington EDA Sign Loan Program: Application

Property Owner Name: Grand K

Property Owners Address: 401 4th Ave NE

Address to be improved: 229 West main

Phone: 651-315-2457 Howard 507-351-1005 Brandon Date: 3-4-21

Short Project Description:

Total Improvement Cost: 2876.00 Loan Request: 4 businesses?

The amount of the loan cannot be more than \$1,000. Limit of one per business.

Contractor Name	Bid Amount
1. <u>Sid's Signs</u>	<u>2876.00</u>
2. <u>Sign Pro Mankato</u>	<u>over 1200</u>

Have you received a loan from the Sign Loan Program in the past? NO

Your application is not complete if you do not include:

1. **Bid/Quote**
(If you are doing the work yourself, attach a copy of the material costs on letterhead from the material supplier)
2. **Sketch/Image of Project**
3. **Sign Permit**
(You may apply without permit; EDA needs it before you receive funds.)

I AGREE with and UNDERSTAND the following:

I have read and am within the guidelines for the Sign Program. I understand that if any information is incorrect or incomplete, my chances of receiving funding will be delayed and/or hindered.

SIGNATURE: [Signature] DATE: 3-4-21

Applications will be reviewed in the order they are received.

Arlington EDA Sign Program

Overview:

This program is intended to offer funds to property owners in the City of Arlington for the purpose of adding, improving or replacing signage. Signage should be designed to enhance and compliment the character of buildings in the City of Arlington.

Loan Rates/Terms:

Loans up to \$1,000 are available. Loans will be in the form of a 0%, 3-year deferred loan. A deferred loan means that you have no monthly payment. If you maintain your business in that building and continue to own the building for the next three years, the loan will be forgiven. If you sell your building or it is no longer used as your principle place of business before the three-years is up, you simply pay back what you owe without interest. No more than one loan will be allowed per business during an eight-year time period. No property owner investment is required for this program.

Eligible Properties:

Eligible properties must be located within the Arlington City Limits.

Eligible Improvements:

Eligible improvement include new signs or the replacement and improvement of existing signs. All signs must follow the City's Zoning Ordinance.

Ineligible Improvements:

Ineligible improvements are signs that are not in compliance with the City's Zoning Ordinance.

Work by loan recipient:

The loan recipient can perform the work, although funds can only be used to compensate for materials. Materials must be purchased, installed and inspected prior to disbursement of the loan proceeds. In either case, a two-party check will be issued payable to both the loan recipient and the materials provider. All permits must be obtained by the loan recipient and work inspected by the City of Arlington and / or other appropriate personnel when required by City Ordinance.

Application Processing:

The EDA Board of Directors will review all applications for final approval. This can take up to one month depending on when you turn in your application. For the fastest service, turn in applications by the first week in a given month.

Contractor / Permits:

A minimum of two bids per project must be obtained from contractors, the lower of which will be reimbursed, unless the work is done by the applicant. All required permits must be obtained, are the responsibility of the loan recipient and must be obtained prior to work commencing on the project.

Total Project Cost:

The EDA will contribute up to \$1,000 towards the cost of replacing, repairing or purchasing new signs. Business must match the amount of the award.

Work Completion:

Weather permitting; all projects must be completed within 180 days of the date the grant is awarded.

Disbursement Process:

After an inspection by the City and / or the EDA to verify completion of the work, a two-party check will be issued payable to both the loan recipient and the contractor or materials supplier. Before funds can be released, the following must be received by the EDA:

- 1) Final, original invoice from contractor (or material list from supplier).
- 2) Completion certificates signed by the loan recipient and the contractor, if there is one.
- 3) Copies of all required city permits (also indicating final inspection by the city when necessary).
- 4) Final inspection by the EDA.

Please allow a minimum of 31 days from the time invoices are submitted for reimbursement checks to be issued. The Arlington EDA approves all expenditures on the 2nd Monday of each month and invoices must be received the Friday prior to the EDA meeting for their consideration. Please advise your contractors of this schedule.

Applications can be dropped off at City Hall or mailed to:

Arlington Economic Development Authority
204 Shamrock Drive
Arlington, MN 55307

The following are some Sign Contractors located in the surrounding area, but you are not limited to these companies:

Signs Plus
2400 South Broadway Street
New Ulm, MN 56073
Phone: (507) 276-8331

New Ulm Signs & Graphix
1901 N Washington Street
New Ulm, MN 56073
Phone: (507) 359-5247

Sign Solutions
1230 N Broad Street
Mankato, MN 56001
Phone: (507) 388-6596

Sid's Signs on Broadway
700 North Broadway Street
New Ulm, MN 56073
Phone: (507) 359-9536

Peter's Signs
2724 9th Street East
Glencoe, MN 55336
Phone: (320) 864-2998

**Please call the Arlington Economic Development Authority
at (507) 720-8586 if you have any questions or need additional information.**



PH. 507-359-9536 * FAX 507-354-3972
700 North Broadway * New Ulm, MN 56073

e-mail: sidssignsonbroadway@yahoo.com
Web: sidssignsonbroadway.com

**NOT TO BE
REPRODUCED**

WITHOUT PERMISSION
*These drawings are
property of:*
SID'S SIGNS ON BROADWAY

Estimate #
011183

Bill To:
City of Arlington 204 Shamrock Drive Arlington, MN 55307

SIGNAGE PROPOSAL

Date
2/17/2021

Qty	Item	Description	Rate	Total
3	Decals	Large window decals for upper windows of building.	275.00	825.00
3	Labor	Labor to install each large window decal	135.00	405.00
1	Sign	Scrolling iron sign bracket with 2 sided sign.	775.00	775.00
1	Labor	Labor to install scrolling iron sign, with anchor chains and turnbuckels (includes use of bucket truck)	775.00	775.00
1	S&H	Shipping charges on iron sign	96.00	96.00
If accepting this proposal.....Please sign.... date.....and return				

Terms: 1.5% interest to be paid on accounts over 30 days.

Total	\$2,876.00
--------------	------------

NO WORK WILL BEGIN UNTIL DEPOSIT IS RECEIVED & PROPOSAL SIGNED.

This estimate is good for 30 days. \$ _____ due at signing and \$ _____ due upon completion.

By my signature below, I authorize work to begin and agree to pay amount in full to the terms on this agreement.

Signature: _____ Date: _____ Amount Paid _____



Outlook

Search

DB

New message

Reply Delete Archive Junk

Favorites

Inbox 507

Sent Items 1

Drafts 158

Add favorite

Folders

Inbox 507

Junk Email 625

Drafts 158

Sent Items 1

Deleted Items 916

Archive

Notes

Allsup

Amazon 64

BSF

Cherish the Children 4

Pricing

BB Ben Bailey <benb@signp
romankato.com>

Fri 2/19/2021 4:21 PM

To: debrinkman@hotmail.com

Hello,

I've got some pricing figured out for you on the signage you're looking at doing in Arlington. Wanted to run it by you to see if it's something you'd like to pursue before I go into proofing anything.

Bracket and blank - \$395 + shipping

Vinyl for sign - \$100

Tenant vinyl - \$55 each, \$165 total

Install of vinyl and bracket - \$350

Total \$1010 + tax and shipping - *Does not include installation*

Let me know if I should go ahead and start the proofing process. Plus I'd need the art from that interior design tenant.

Thanks!!

Ben Bailey

Sales

SIGN PRO MANKATO

P - 507-345-3388

D - 507-386-2043

C - 507-340-3038



Reply Forward

INSTALLED TOGETHER:
 1.) 1201-WM-FRM-V3624
 2.) AB100-V3624-100

REVISIONS			
REV	DESCRIPTION	DATE	CS
A	ORIGINAL DRAWING	9/2015	CF
B	UPDATED OVERALL DIMS.	4/5/2018	CF

(2) GUY-WIRE RINGS



TOP VIEW

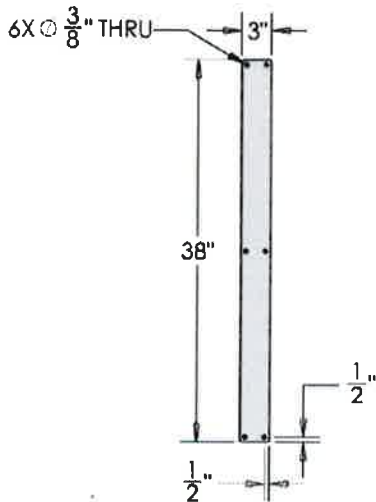
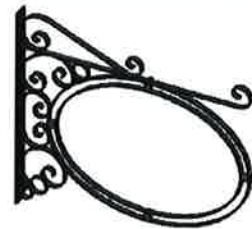

SIDE VIEW

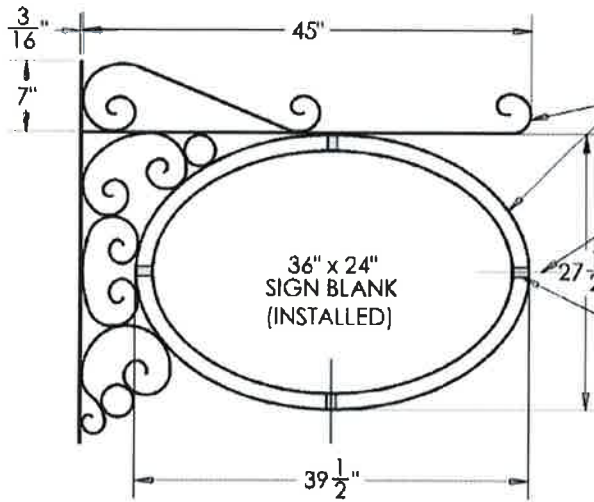

FRONT VIEW

SCROLLWORK & OVAL FRAMES:
 1/8" x 1" STEEL FLAT BAR

4X ϕ 3/8" SIGN MOUNT HOLES
 THRU FRAME & SPACERS

1" x 1" x 1 1/2" STEEL SQUARE TUBE SPACERS

Material: Steel

Content: Wall Mount Oval Sign Frame w Scroll 36"x24"

Scale: 1:14

PN: 1201-WM-V3624-100

DB: CF

Color/Finish: Textured Black Powder Coat

Rev: B

Customer Approval: _____

Sheet: 1 of 1

New Ulm, MN
 507-359-9536



actual size of the window 25-1/2" x40-1/2"

point *of* view
I N T E R I O R S



windows • walls • spaces

320-491-6854

www.povinteriors.com

actual size of the window 25-1/2" x40-1/2"



Sight Line
Photography
by Gwen & Tanis

Gwen: (612) 227-0030 Tanis: (952) 567-3363
sightlinephotography@outlook.com

actual size of the window 25-1/2" x40-1/2"

MATZ FLOORING

Suite 103

Jeff Matz

507-381-3754

- 
- Wood Floors
 - Ceramic Tile
 - Carpet

Sign Permit

Return all Applications to: City of Arlington, Building Department
 204 Shamrock Drive, Arlington, MN 55307
 Phone: 507-964-2378 fax: 507-964-5973
 Zoning Official: Amy Newsom—Planning and Zoning Administrator

Office Use Only	
Permit Number:	<u>A2021-18</u>
Date Received:	_____
Sign Permit fee:	\$26.25
Plan Review:	Based on Value
Total:	\$ <u>26.25</u>

Site Address or Location: 229 West main
 Zoning District: Commercial Number of Sides: 3 1 side 1 2 sides
 Square Footage of Sign: decals off sign 72 sq ft Front Footage of Property: 100'
 Type of Sign: 3 window decals 1 hanging Height (above ground): 10'
 Will the Sign be Lighted: NO YES, How So: _____

The applicant must also supply with this Permit Application the following:

- An explanation or drawing showing location of existing and proposed buildings on site
- The location of existing buildings within 100 feet of the site
- Location and Height of all existing and proposed signs on the site, complete with route of electrical signs if needed
- All specifications and dimensions of signs including the lettering size and graphics
- Description of sign and frame materials and colors, including supports
- If it is a wall sign, include the anchorage details

More information required on next page:

Contact Person: Brandon Brinkman Phone: 507 - 351-1005

Address: 401 4th Ave NE Arlington, mn 55307

I hereby certify that I have completed, read and examined this application and know the same to be true and correct, I accept responsibility for compliance with all applicable laws, notifications, and city provisions. The granting of this permit does not presume to give authority to violate or cancel the provision of any other state or local law regarding construction or the performance of construction.

Applicant Signature:  Date: 3-4-21

Applicant's Name Printed: Brandon Brinkman

Approved Denied

Authorized Approval Signature:  Date: 3-4-21

acre: ten (10) square feet per surface with total area of all signs not to exceed twenty (20) square feet.

- (3) Lots greater than one (1) acre but less than ten (10) acres: twelve (12) square feet per surface with total area of all signs not to exceed twenty-four (24) square feet.
- (4) Lots greater than ten (10) acres: sixteen (16) square feet per surface with total area of all signs not to exceed thirty-two (32) square feet.

b. Lots containing principal uses which are non-residential in nature.

- (1) Lots less than twenty thousand (20,000) square feet: thirty-two (32) square feet per surface with total area of all signs not to exceed sixty-four (64) square feet.
- (2) Lots of twenty thousand (20,000) square feet or greater: sixty-four (64) square feet per surface with total area of all signs not to exceed one hundred twenty-eight (128) square feet.

B. B-1 Service Business District:

1. The following types of signs are not permitted:

- a. Rotating signs.
- b. Projecting signs.

2. Maximum sign area:

- a. The total area of all signs shall not exceed two (2) square feet per lineal foot of lot frontage, ten (10) percent of the building's front façade, or seventy-five (75) square feet, whichever is greater. For corner lots, the "lot frontage" used to determine allowable sign area shall be the least dimension along a street, but an equivalent sign area shall be allowed facing the intersecting street.
- b. The number of off-premise signs shall be limited to one (1) per one hundred (100) feet of lot frontage. Such off-premise signs may contain up to two (2) signs per facing; however, each sign face shall not exceed fifty-five (55) feet in total length. No off-premise sign may be erected within one hundred (100) feet of an adjoining residential district.
- c. No sign shall project higher than six (6) feet above the height of the building, or thirty-two (32) feet above average grade at the building line, whichever is greater.

C. B-2 Central Business District:

1. The following types of signs are not permitted:

- a. Flashing or rotating signs.

b. Off-premise signs.

2. The total area of all signs shall not exceed two (2) square feet per lineal foot of lot frontage, ten (10) percent of the building's front façade, or seventy-five (75) square feet, whichever is greater. For corner lots, the "lot frontage" used to determine allowable sign area shall be the least dimension along a street, but an equivalent sign area shall be allowed facing the intersecting street.
3. No sign shall project higher than six (6) feet above the height of the building, or thirty-two (32) feet above average grade at the building line, whichever is greater.

D. I-1 Light Industrial District:

1. The following types of signs are not permitted:
 - a. Rotating signs.
 - b. Projecting signs.
2. The total area of all business signs on a lot shall not exceed three (3) square feet of each lineal foot of lot frontage or twenty (20) percent of the building frontage or three hundred (300) square feet in area, whichever is greater. Such signs may be illuminated.
3. Advertising sign structures shall be limited to one (1) for a lot of one hundred (100) foot frontage or less and to only one (1) for each additional one hundred (100) feet of additional lot frontage. Such structures shall not exceed fifty-five (55) feet in length. No advertising sign may be erected within one hundred (100) feet of a residential district. Such signs may be illuminated.
4. Sign lighting shall not be directed toward a public right-of-way or any residential district.

E. I-2 Heavy Industrial District:

1. The following types of signs are not permitted:
 - a. Rotating signs.
 - b. Projecting signs.
2. Signs as regulated in Subdivision 8 (D) (2) (Light Industrial District) of this Section.

F. P/I Public Institutional District:

1. The following types of signs are not permitted:
 - a. Projecting signs.
2. Sign lighting shall not be directed toward a public right-of-way or any residential district.

Amy Newsom

From: Craig Buss
Sent: Thursday, March 4, 2021 7:32 PM
To: Amy Newsom
Subject: Tractor pull

Here is what I have came up with.

Dates june 19th or july 2nd.

Start time 5pm with rpm classes and or field tractors

Then the UMP NTPA classes at 6 or 7pm

2 options to decide on for the pull are either use the NTPA group with the RPM (local hot farm) or just the RPM and schedule a separate skid and track crew. The fee the UPM group charges includes a NTPA skid, tech crew, flaggers, scale and a announcer. We would need to provide the announcing equipment. For both options. If we have the UPM group come to town they have the event listed on the NTPA web site and get a nation wide audience. I should have the contract for the UMP group by monday night to go over exact costs. We will need to discuss seed money that will be needed to cover costs until we would collect monies from pledged sponsors and ticket sales. Pledges will be in writing signed by sponsors.

Sponsorships discussed with other groups are as listed.

Per \$2000 sponsorship

5 vip passes and 10 pit passes.

Per \$1000 sponsorship

10 pit passes.

Per \$500

5 general admission passes

Ticket sales would be with city businesses and the EDA board? Perhaps to include the chamber they could assist. Choose Arlington could be used for a main point of advertising and recieve some of the proceeds.

Liquor sales would need to stay with Arlington businesses 2 points of liquor/ beer sales needed

Food sales need to be Arlington businesses

2 points of food sales needed.

We would ask all businesses for advertising to place around location of event parking and pulling track.

Recommended admission

Vip-\$50

Included with this is the pits and puller stationing up close to pullers and track. And shade trees. No bleachers provided.

Also free donated beer and liquor till donated amount is gone.

Pit pass - \$25

Access to pits and up close with tractors and pullers.

General Admission-\$10

Ages 10-15 -\$5

Ages 10 and under free

All pullers non NTPA for RPM classes would pay \$25 hook fee

Items needed would be bleachers, snow fence, volunteer for ticket admission 2 light bars and 3 smaller sized generators.

Insurance. Waiting for NTPA to issue what would be needed.

270 seating bleachers \$1300

Other items waiting on fee schedule.

Contact county for use of light bar and 2 deputies?

Will have all fee schedules by monday night to go over.

Things to consider, whatever day the tractor pull is, plan to have a diesel truck show at 4 seasons park or on Henderson Rd by Northland Drying. And the day following saturday or sunday have the Mn Minne rods in town. A band up town might be a big hit for a friday or Saturday night to keep people in town and the tractor pullers like to have a bite to eat and something to wash it down.

We are checking what side of Northland Drying to have the pull, either the side closest to hwy 5 or off henderson rd.

I would recommend giving each business in Arlington 2 general admission tickets to do what they deem. In Hope's they can use it to draw customers into business. I'll send pics of aerial photos in the am.

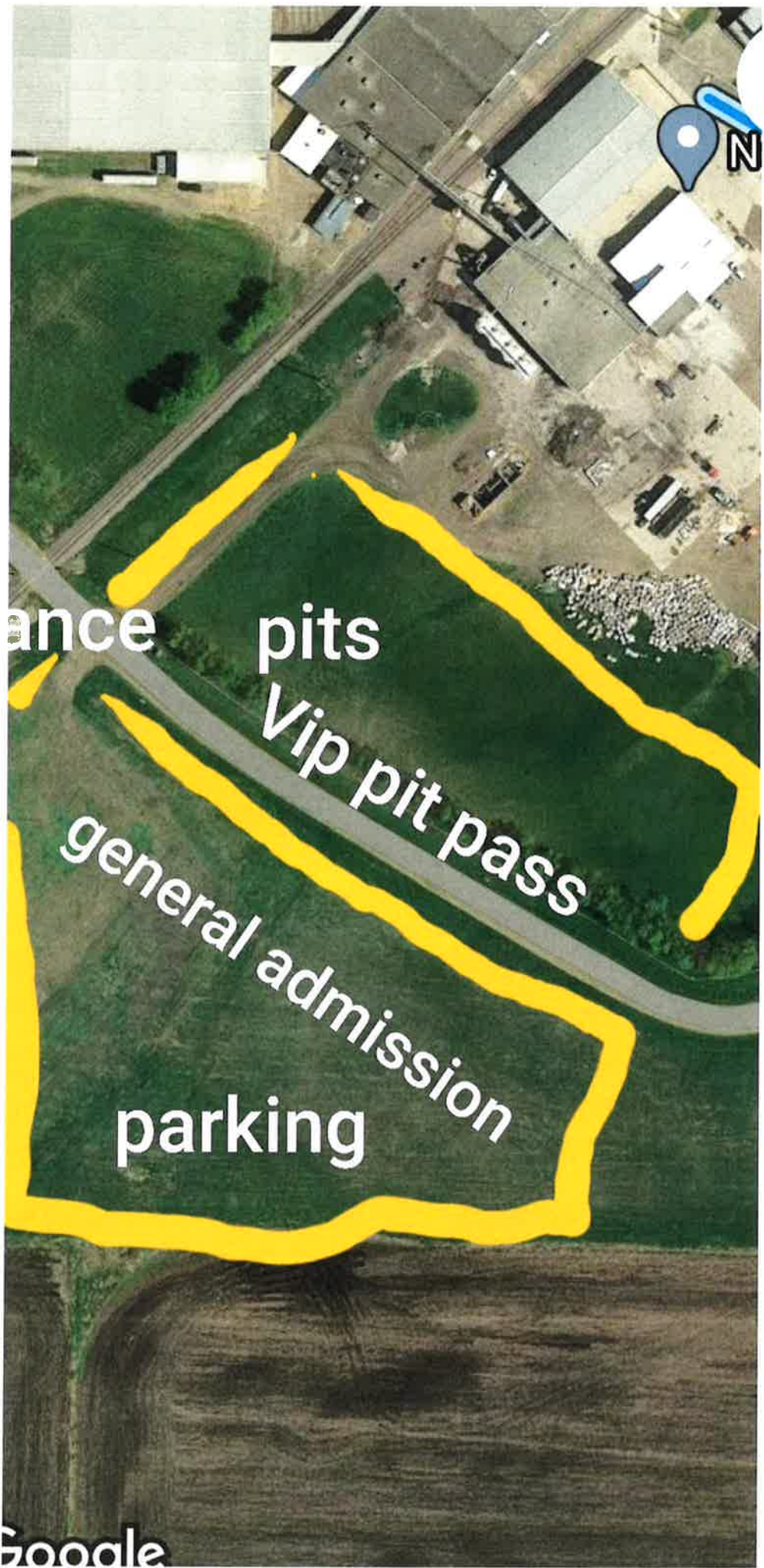

ance

pits

Vip pit pass

general admission

parking

Google



Northland Drying

Henderson Rd

vip pit pass

entrance
Google

General admission

100 ft
20 ft





PUBLIC HEARING FOR PROPOSED DOG PARK



The Arlington Economic Development Authority (EDA) will hold a public hearing regarding the construction of a dog park in the City of Arlington.

ATTEND THE PUBLIC HEARING

All Arlington residents are invited to attend the public hearing of the EDA to express their opinions on the proposed dog park:

Monday, March 8, 2021 at 6:00 p.m.
Arlington Community Center – Council Chambers
204 Shamrock Drive
Arlington

Comments can also be sent to EDA Director Amy Newsom at 204 Shamrock Drive, Arlington, MN 55307 or anewsom@arlingtonmn.com.

Dated: 2/17/2021

Posted: 2/25/2021

